

Rolv Gjestland

# How to design a cinema auditorium

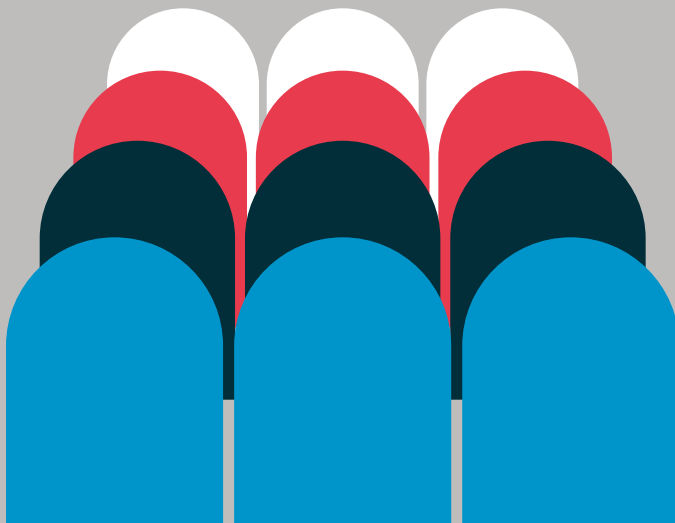

Practical guidelines for architects, cinema owners and others involved in planning and building cinemas

Rolv Gjestland

How to design  
a cinema auditorium



UNION INTERNATIONALE DES CINÉMAS  
INTERNATIONAL UNION OF CINEMAS

### How to use this book

This book can be read from beginning to end, to learn more about the elements that need to be taken into consideration when designing a cinema auditorium. But it may also be used as a reference in the design process, as the different parts of the auditorium are planned. Just be aware that making a change in one element might affect others.

Designing a cinema auditorium is quite easy if you follow the rules. Although, if everyone follows all the rules, all auditoriums will look the same. Go beyond the rules, but always keep in mind that the main purpose of a cinema auditorium is to give the audience the best film experience. In addition, there are many other rooms in a cinema complex where you can use your creativity to create great experiences for patrons and make them want to come back.

A digital version of this book is also available on the UNIC website: [www.unic-cinemas.org](http://www.unic-cinemas.org)

### Feedback

This is the second edition of the book, and still I am sure someone will miss something, someone will disagree with something and something will be incomplete or difficult to understand. Please do not hesitate to share your opinions, so the next edition can be better and the next one after that ... Please use the contact details on the next page.

## About the author

Rolv Gjestland has a master's degree in metallurgy from the Norwegian University of Science and Technology. He is now advisor in cinema concepts, design, logistics and technology for Film& Kino, the nonprofit trade organisation for Norwegian cinemas. Since 1984, he has been involved in almost every newbuild or upgrade of cinemas in Norway. He has written projection manuals – both for analogue and digital cinema – and manuals and articles about cinema design (available in Norwegian).

He started his career as a cinema-goer at a very young age and considers this to be one of his most important skills. Over the years, he learned a lot about improving the cinema-going experience, both in the auditorium as well as in the lobby and the rest of the cinema complex. In doing so, he has acquired a great deal of knowledge and expertise about operating cinemas, effective logistics and facilitating the efficient use of staff – without ever sacrificing the quality of the experience.

One of his slogans is: “A film production is not finished until the film is presented to the audience,” and that cinemas are the only place that can guarantee film presentation as intended by the filmmaker.

### **Contact:**

Rolv Gjestland, c/o Film&Kino  
Dronningens gate 16, N-0152 Oslo, Norway,  
Tel: +47 95208502  
Email: rolv@kino.no

## About UNIC

The International Union of Cinemas (UNIC) is the European trade body representing national cinema associations and key operators across 38 territories, covering over 42 500 screens and over 1.34 billion cinema-goers in 2019.

UNIC promotes the cultural, social and economic benefits of a vibrant cinema-going culture in Europe and provides a strong voice for European cinema operators on issues of shared interest.

Like millions across Europe, we love cinema and very much look forward to a bright future for our industry. We hope that this book will encourage many of you to design state-of-the-art auditoriums, where film lovers will be able to enjoy the unique experience of watching films together, on the Big Screen.

### **Contact:**

Union Internationale des Cinémas /  
International Union of Cinemas  
Avenue des Arts 10–11, 1210 Brussels, Belgium  
Tel: +32 2 8809939  
Email: communications@unic-cinemas.org

Foreword	10
Introduction	11

## 1 Screens 13

---

<b>1.1</b>	<b>Screen shape</b>	13
1.1.1	Aspect ratio	13
1.1.2	Curved or flat screens	15
1.1.3	Non-rectangular screens	18
<b>1.2</b>	<b>Position and tilt</b>	18
1.2.1	Horizontal position	18
1.2.2	Vertical position	19
1.2.3	Depth behind the screen	19
1.2.4	Tilting the screen	20
<b>1.3</b>	<b>Size</b>	21
<b>1.4</b>	<b>Screen surfaces</b>	26
<b>1.5</b>	<b>Perforations</b>	28
<b>1.6</b>	<b>Seams</b>	30
<b>1.7</b>	<b>Mounting systems</b>	30
1.7.1	Lace-in frame	30
1.7.2	Wrap-around frame	31
1.7.3	Roll-up screens	32
<b>1.8</b>	<b>Masking and curtains</b>	34
1.8.1	Screen masking	34
1.8.2	Adjustable masking	35
1.8.3	Space for movable side-masking	36
1.8.4	Curtains	38

## 2 Projection 41

---

<b>2.1</b>	<b>Room for the projector</b>	41
2.1.1	Projection room	41
2.1.2	Projector cabinet	43
2.1.3	Boothless projection	43
<b>2.2</b>	<b>Projection angle</b>	46
2.2.1	Distortion	46
2.2.2	Lens shift	48
<b>2.3</b>	<b>Porthole</b>	48

2.3.1	Porthole size	48
2.3.2	Porthole, horizontal position	50
2.3.3	Porthole, vertical position and clearance under the projection beam	51
2.3.4	Porthole glass	51
2.3.5	Fire protection	53

## 3 Direct view displays for cinema 55

---

<b>3.1</b>	<b>Display format</b>	56
<b>3.2</b>	<b>Display size</b>	56
<b>3.3</b>	<b>Depth behind the display</b>	57
<b>3.4</b>	<b>Luminance</b>	57

## 4 Viewing conditions 61

---

<b>4.1</b>	<b>Screen to first row distance</b>	61
<b>4.2</b>	<b>Horizontal viewing angles</b>	62
<b>4.3</b>	<b>Vertical viewing angles</b>	64
<b>4.4</b>	<b>Seating outside the screen's edges</b>	66
<b>4.5</b>	<b>Safety area in front of large cinema projectors</b>	66
<b>4.6</b>	<b>Seating area</b>	67
<b>4.7</b>	<b>Sightline clearance</b>	68
<b>4.8</b>	<b>Stairways in the aisles</b>	71

## 5 Seating 75

---

<b>5.1</b>	<b>Seating row distance</b>	75
5.1.1	Escape width	76
5.1.2	Last row depth	77
<b>5.2</b>	<b>Seating types</b>	78
5.2.1	Depth	79
5.2.2	Width	81
5.2.3	Height	82
<b>5.3</b>	<b>Seating quality</b>	82
5.3.1	Cushion density	83
<b>5.4</b>	<b>Curved seating rows</b>	84
<b>5.5</b>	<b>Offset seating rows</b>	86

5.6	Aisles	87
5.6.1	Crossing aisles	87
5.6.2	Handrails	89
5.7	Mounting seats	90
5.8	Sightline issue with recliners	91
5.9	Stadium construction	92

## 6 Stray light 95

---

6.1	Optical errors	95
6.2	Reflected light from the screen	95
6.3	Other light sources	97
6.3.1	Exit doors	98
6.3.2	Light from the projection room	98
6.3.3	Other light sources and visible elements	99
6.4	Room colours	99
6.5	Ceiling	100

## 7 Lighting 103

---

7.1	House lighting	103
7.1.1	Luminaries	104
7.1.2	Other lights	105
7.1.3	Light levels	106
7.1.4	Light control	106
7.2	Emergency lighting	107
7.2.1	Exit lights	107
7.2.2	Stair lighting	108
7.2.3	Guiding lights	109

## 8 Acoustics 111

---

8.1	Sound isolation	111
8.1.1	Doors	112
8.1.2	Vestibule	112
8.2	Background noise	113
8.3	Reverberation	115

8.4	Echo	117
8.5	Wall surface	118

## 9 Speaker placements 121

---

9.1	Front speakers	122
9.2	Subwoofers	125
9.3	Rear surround speakers	126
9.4	Side surround speakers	127
9.5	Mounting surround speakers	129
9.6	Baffle wall	130
9.6.1	The room behind the baffle wall	134

## 10 Auditorium shapes 137

---

10.1	Room height	137
10.2	Parallel side walls	139
10.3	Angled side walls	139
10.4	Projection room above the rear part of the auditorium	141
10.5	Balcony	142

## 11 Accessibility 145

---

11.1	Wheelchairs	145
11.1.1	Wheelchair access	145
11.1.2	Ramps	146
11.1.3	Space for wheelchairs	147
11.1.4	Number of wheelchair spaces	148
11.1.5	Wheelchair locations	148
11.1.6	Entrance and exit doors	149
11.2	For hearing impaired people	150
11.3	For visual impaired people	151

---

Thanks	152
Literature	154

## Foreword

The intention of this book is to give architects, cinema owners and managers, as well as other people involved in the process of planning and designing cinemas, some support in the design process.

Some aspects, especially regarding security, safety and accessibility must comply with local or international regulations. There are also the laws of nature and physics that cannot be changed, such as optics or anthropometry.

The topics discussed mainly focus on design and less on technology, such as projectors, audio equipment, the electrical system or the ventilation system.

I have tried to be as neutral as I can, but my personal views might sometimes shine through.

Not all seats can be perfect, and a completely pitch-black screening room might not look so nice. Designing an auditorium always includes a lot of compromises. This little book will hopefully help in achieving the best compromises.

I wish you luck and hope this guide will contribute to the design of great cinema auditoriums, where audiences will be able to enjoy unforgettable experiences.

## Introduction

What we know as Digital Cinema is a global format based on specifications made by the Digital Cinema Initiative (DCI) and standardised by the Society of Motion Picture and Television Engineers (SMPTE).

One key principle of DCI is that all pictures must fit within the image container, which can be either 1080 x 2048 pixels (2K) or 2160 x 4096 pixels (4K).

The image files are compressed and distributed together with the audio, subtitles and all the other necessary files in a digital package called a DCP (Digital Cinema Package). Image, sound and subtitle files may also be encrypted to prevent illegal use of the DCP.

The dominating way of showing a film in a cinema auditorium is by projecting pictures on a screen. Direct view displays for cinema, using active LED technology, have recently been introduced. With such systems there will no longer be a projection beam passing through the room, above the head of the audience, and there is no need for a projection room. But, apart from that, direct view displays will not significantly change the way cinema auditoriums will be designed in the future.

# 1 Screens

The screen is one of the most important elements in a cinema auditorium. The room design depends, for a large part, on the screen type, size, shape and position. Before making the final design drawings, the type of screen surface should be decided, as it might limit the acceptable seating area.

Projection screens are usually made of coated PVC, but there are also woven and nano-engineered screens. PVC screens are white or silver coated, and usually perforated so as to let sound pass through them.

## 1.1 Screen shape

### 1.1.1 Aspect ratio

Picture format is a basic choice a filmmaker must make in order to tell the story. Over the years, filmmakers have experimented with many different formats but, following the digitisation of cinemas, two formats stood out: 1.85:1 (also known as “Flat”) and 2.39:1 (also known as “Scope”).

The Scope format is used to tell the story on a big, very wide screen and is meant to be the widest format in a regular cinema. Other formats will then use the same, fixed, screen height. The screen

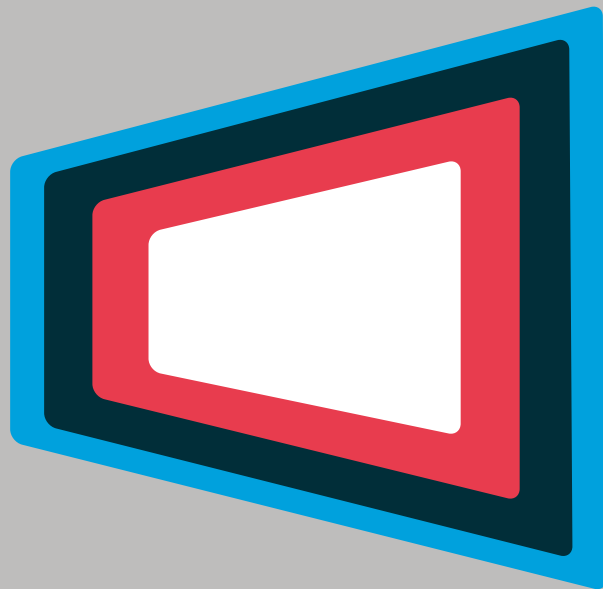



height is therefore always 1 in cinema aspect ratios, unlike television or computer screens where it can be 4:3, 16:9, etc.

Other formats can be used if the room is too narrow for a good Scope screen, or if special systems – such as IMAX, Dolby Cinema or 70mm film – are going to be screened. There may be various other reasons for selecting screen formats, which we won't list here.

Some filmmakers decide to make their films in other aspect ratios than Flat or Scope, or what is often referred to as “non-standard” aspect ratios. Content with aspect ratios smaller than 2.39:1 usually fills the screen height on a 2.39:1 screen with black (no picture) columns on each side, called a pillarbox. Larger aspect ratios must be letterboxed, with black bars above and under the image. In rare occasions the picture might be both letterboxed and pillarboxed, sometimes called windowboxed.

On a 1.85:1 screen, all aspect ratios above 1.85:1 will be letterboxed. If that is the case, one must decide the picture's vertical position on the screen:

- **Same picture centre for all formats**, which results in different levels for the picture bottom and top line. If screen masking is used, there must be movable top and bottom masking.
- **Same bottom picture line**, where the picture centre and top level varies with selected format. Also, the projection angle will depend on the format. With screen masking, only moveable top masking is required.

- **Same top picture line**, with variable centre level and projection angle. The vertical sightlines from the first seating row to the picture centre might be uncomfortable for the audience in wide formats (2.39 and such). If the picture is masked, there must be moveable bottom masking. This alternative is rarely used.

It is important, and required by DCI, that all active pixels are visible on the screen. Making a compromise on screen aspect ratio and cropping the pictures to fit the screen height and width in any format is not acceptable.

### 1.1.2 Curved or flat screens

The screen can be either flat or curved. For practical reasons, screens are only curved horizontally. Both vertical and horizontal curving would demand a special solution, like a vacuum chamber behind an unperforated screen. Such domed screens, if they still exist, are not discussed in this book.

When choosing between flat or curved screens, there are some factors to take into consideration:

- Standard projection lenses are designed to give best focus and geometry on flat screens.
- The picture geometry will look better on a flat screen when viewed from seats with a large angle to the screen centre.

— If the depth behind the screen is limited in the centre, the edges must be pushed out closer to the front rows, where the field of view will be larger. Because of limitations in terms of maximum field of view, it may require removing the first row (see fig. on facing page).

— A flat screen can have a matte, white surface. It may require a more powerful projector to achieve correct luminance on the screen, but it will give the best picture quality for all seats.

— A curved screen must have a gained screen surface (see Screen surfaces section later in the book), which prevents reflection from one side of the screen to the opposite side, reducing the contrast (black level) on the sides.

— A gained screen should be curved, to even out the luminance across the screen and keep the hotspot (area with higher luminance) closer to the centre of the screen when observed from the sides of the auditorium.

— A curved screen may give the auditorium a more “classical” look and enhance the sense of immersion, like in the days of 70 mm film, Cinerama format, etc.

— DO NOT use deep curved screens. 5% curve is a good compromise, meaning that the chord depth (sagitta) is equal to 5% of the chord length (the straight line between the screen edges).

— On a curved screen, a straight horizontal line projected on the screen will be slightly curved (see fig below). Larger angles, larger screens and deeper curved screens increase the curve.

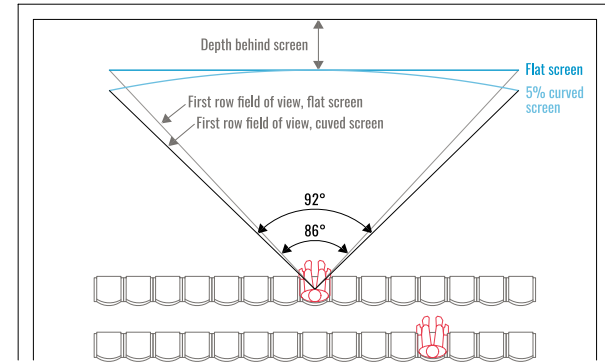

► If the depth behind the screen is limited, curving a screen (with a fixed width) will increase the field of view and can make the viewing conditions on Row 1 unacceptable

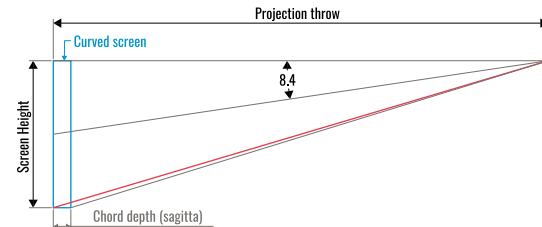

SIDE VIEW

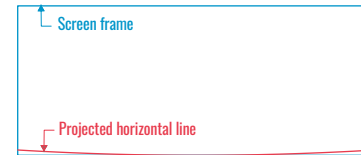

FRONT VIEW

► A straight horizontal magenta line projected in the bottom of a 5% curved cinema screen. Here, the top of the beam is horizontal, the vertical projection angle is 8.4° and P/H=3.4, where projection throw is P, picture height is H.

### 1.1.3 Non-rectangular screens

To compensate for projection on a curved screen, the top and bottom edge of the screen might be slightly curved according to the projected top and bottom lines. This way, the curved line in the bottom will follow the screen's bottom edge and look straight to the audience, if the screen is not too deeply curved.

## 1.2 Position and tilt

A wall-to-wall, floor-to-ceiling screen will make the screen look bigger (and more impressive) but, when it comes to the low bottom edge, it rarely delivers acceptable viewing conditions.

### 1.2.1 Horizontal position

Usually on a floor plan, the centre of the screen axis should be the same as the room centre axis, but this is not always the case:

- \_\_\_ If the seating area is not centric to the room and the screen width is not wall-to-wall, the centre of the screen might have the same centre axis as, or closer to, the seating area.
- \_\_\_ If the projector is not on the room's centre axis, the screen might be placed on, or closer to, the projection axis to achieve less distorted projection.

- \_\_\_ If the screen is not wall-to-wall, and access behind the screen is not possible on both sides of the screen, the screen could be placed a little off the room's centre axis to enable access behind the screen from one side.

### 1.2.2 Vertical position

The bottom picture line (BPL) should be as low as possible, given that the sightline clearance is acceptable and that the Projection Down Angle is not too big (see Projection angle section later in the book). One way to create the illusion that the BPL is lower is to have a little stage or podium in front of the screen. This can also be useful for introductions, presentations, panel discussions, etc.

### 1.2.3 Depth behind the screen

If the front speakers are placed behind the screen, there must be enough depth behind the screen for the speakers as well as access to them. Large auditoriums usually have larger speakers with larger depths. As a rule of thumb, the depth should be a minimum of 1200 mm. If the distance from the screen to the last row is less than approximately 15 m, the depth can be reduced to 1000 mm. Even with thinner loudspeaker models, the depth behind the screen should always be large enough for access to the speakers.

Some systems use speakers above the screen, so access behind the screen is not necessary and the screen can be placed closer to the wall.

#### 1.2.4 Tilting the screen

To compensate for a large projection angle/keystone (see Projection distortion section later in the book), the screen may be slightly tilted. But a tilted screen has some disadvantages, especially when it comes to screen masking (described later in the Screen chapter). Tilted screens will not be as aesthetically pleasing as vertical screens. If tilting the screen is necessary, the tiltback angle should never exceed  $3^\circ$ .

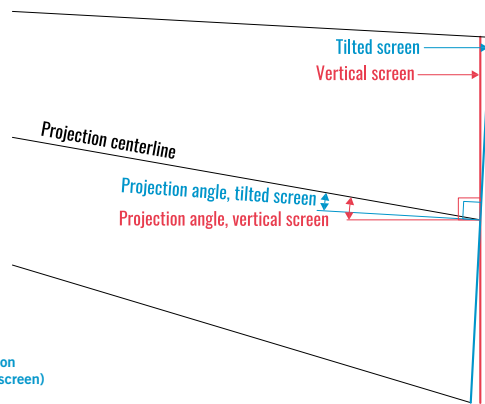

► Reducing the projection angle (relative to the screen) by tilting the screen.

Another reason to tilt the screen could be to optimise the screen for better luminance across the seating area. Usually, this will demand tilting the screen forward. It might be done in flat or close to flat auditoriums, however, it is not recommended in regular cinema auditoriums with stadium seating.

## 1.3 Size

A good, modern cinema auditorium for big films should have a large screen. The larger the better (usually), but larger screens demand a larger distance from the first row to the screen and will allow less seats, so the screen size will usually have to be a compromise.

Not all films look best on huge screens, therefore in some cases a moderate screen size might be better.

The auditorium's size and shape will define how big the screen will look. In a rectangular room, you can use the field of view to decide the screen size, or it's even easier to use the ratio between the viewing distance and the screen's width or height.

**For 2.39:1 aspect ratio screens:**

For an auditorium with more than 4–6 rows, use the distance from the screen to the last row to evaluate the screen size, as shown in the diagram below.

**Screen seen from last row on a 2.39:1 screen**

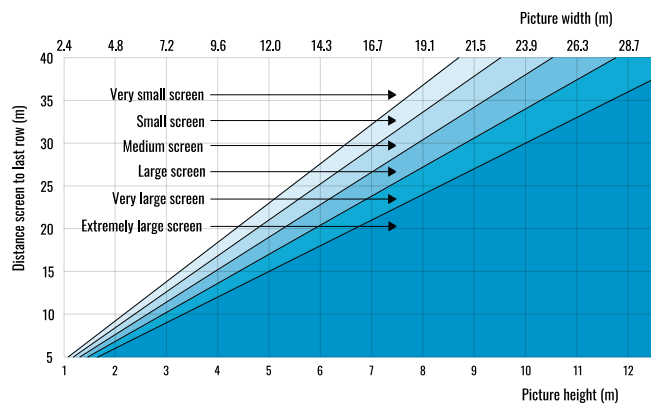

In an auditorium with less than 4–5 rows, or if the distance from the screen to the first row is very large, it might be better to calculate the screen size using the distance from the screen to the centre row (best seat), as shown in the diagram below.

**Screen seen from centre row on a 2.39:1 screen**

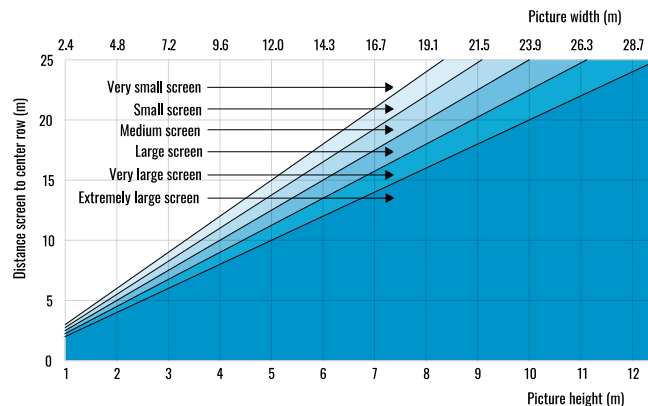

**For 1.85:1 aspect ratio screens:**

In a given auditorium, a 1.85:1 aspect ratio screen should have a smaller width and a larger height than a 2:39:1 screen. For an auditorium with more than 4–6 rows, use the distance from the screen to the last row to evaluate the screen size, as shown in the diagram below.

**Screen seen from last row on a 1.85:1 screen**

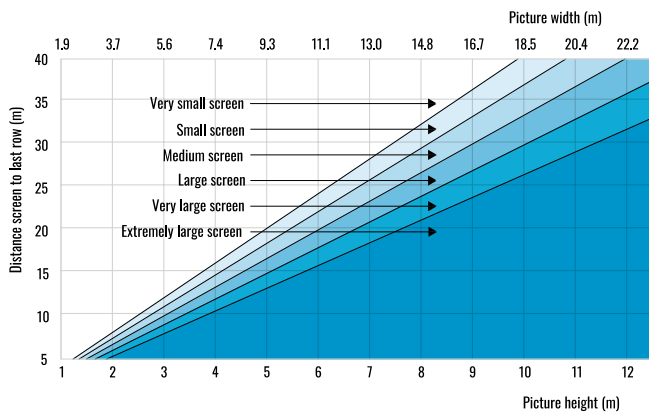

In an auditorium with less than 4–5 rows, or if the distance from the screen to the first row is very large, it might be better to calculate the screen size using the distance from the screen to the centre row (best seat), as shown in the diagram below.

**Screen seen from centre row on a 1.85:1 screen**

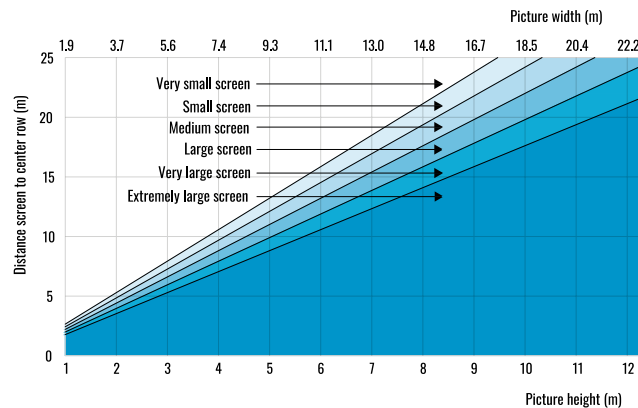

## 1.4 Screen surfaces

Most cinema screens are made of white or silver coated PVC. There are also other types, made of nano-engineered material or woven screens.

Choosing the right type of screen and coating is important and has consequences for the auditorium design. The screen gain tells us how much of the incoming, projected light is reflected on the centre axis. The gain is measured in a lab, on the screen axis, relative to a reference surface with 1.0 gain. A high gain screen will reflect more light on its axis, but the luminance will decrease with increasing viewing angle, as shown in the graph below.

There are many factors to consider when calculating how the screen luminance will look from different seats, but the gain table can be used to get an indication of the consequences. An acceptable viewing angle is often given by the Half Gain Angle (HGA), the angle where the luminance is 50% of the nominal.

— Matte white screens will give a nice and even reflection to all seats in the auditorium. However, there will also be larger loss because more of the light will be reflected to areas outside the seating area. Using a matte white screen will demand a more powerful light source.

**Gain +/- 1.0, HGA > 60°**

— White gained screens are mainly used for 2D and for 3D with active glasses or colour separation (WMT/Infitek/Dolby) systems.

**Gain 1.4–1.8, HGA 30–35°**

— Silver screens are mainly used with polarised 3D systems. Silver screens used to have very high gain, but in recent years new types have been developed with lower gain and more even light reflection. The screen will partly depolarise the light, given by the extinction ratio. Values over 100 are good, while values below 75–80 will result in unacceptable 3D ghosting, depending on light levels and other factors.

**Gain ~1.7 – ~3.0, HGA 20–30°**

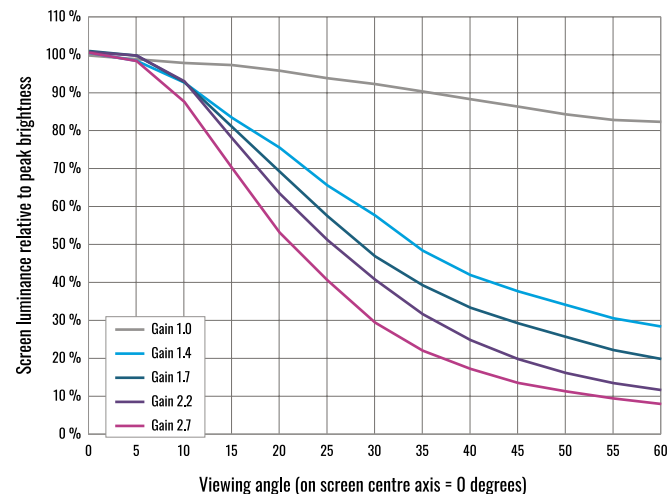

► Relative screen luminance (examples) vs viewing angles for various screen types.  
NOTE: Different screen types may deviate from these curves, even if they have the same screen gain, so always check with the manufacturer.

The choice of screen surface will have consequences for the picture quality and acceptable seating area (see Horizontal viewing angle section later in the book). See, as an example, the illustration below with two different screen types in the same room.

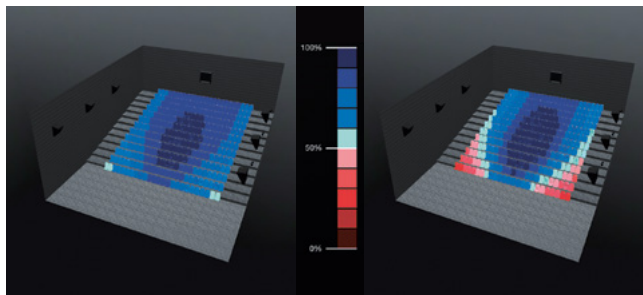

► Acceptable seating area in the same room configuration, with two different screen types. Left: Harkness Perlux HiWhite 140; Right: Harkness Clarus 220. The illustration was generated by Harkness Digital Screen Modeller (available on their website). N.B. Acceptable seating area will depend on other factors too, so each case must be treated individually.

## 1.5 Perforations

Usually, the front loudspeakers are located behind the screen, to match the location of the sound with the action on the screen. Therefore, for acceptable sound quality, the screen must be perforated. For good sound transmission, the total open area (the sum of all perforations) should be in the range of 4–5%.

Standard perforations have a diameter of 0.9–1.1 mm. If the distance from the screen to the viewer is less than 4–5 m, the perforations will be visible from the first row(s), and a screen with smaller perforations must be used.

Standard perforations can interfere with the projected pixels, especially in 4K resolution, resulting in a *moiré* pattern on the screen (see below). A screen with smaller perforations (0.4–0.8 mm) will cancel the moiré effect.

Many screen manufacturers have screens that are designed to avoid moiré and improve sound transmission, using small perforations ( $\varnothing < 0.6$  mm).

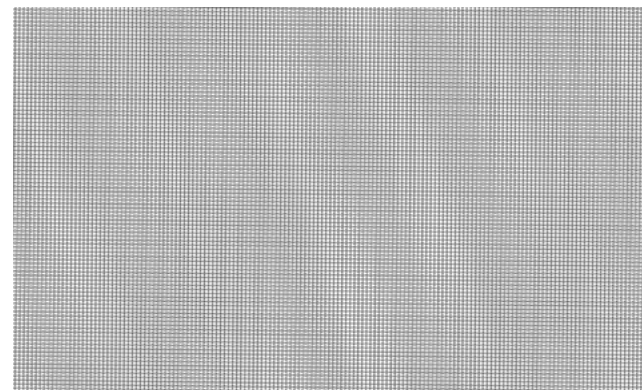

► Moiré pattern



## 1.6 Seams

To make larger screens, sheets of screen material are welded together. When doing so, the perforation pattern must match perfectly between each of the sheets. Even a tiny deviation in the pattern will be visible as a grey vertical or horizontal line that can be seen from all seats in the auditorium.

Screens with high-density small perforations might be impossible to weld, as the surface available for the seam is too narrow. Such screens might therefore not be available in large sizes.

## 1.7 Mounting systems

There are different methods of mounting the screen in a cinema auditorium. The most common are described below.

### 1.7.1 Lace-in frame

With lace-in frame systems, the frame is bigger than the screen. The screen is delivered with a folded edge with eyelets all around. The screen is stretched inside the bigger frame using a cord (similar to a trampoline). To avoid conflict with the lacing and eyelets, the maximum picture size must be a minimum of 200–300 mm smaller than the frame width and height (100–150 mm for each edge).

To hide the frame, lacing and folded edge with eyelets, the screen edges must have matte black masking.

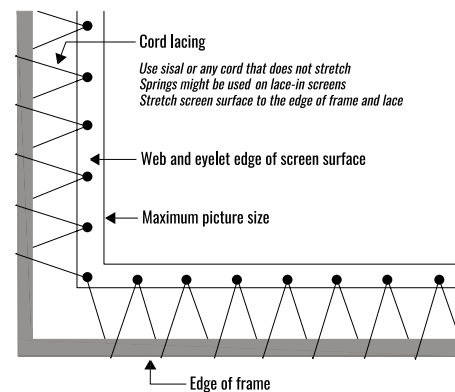

► Lace-in screen mounting, rear view.  
(Source: Harkness screens)

### 3.7.2 Wrap-around frame

Another way of mounting the screen is to use a frame size that matches the largest picture height and width. The screen is wrapped around the frame, called a wrap-around screen or sometimes a “floating screen”. The frame size and the maximum picture size will be the same. With this method, it is possible to make a wall-to-wall and/or floor-to-ceiling picture size.

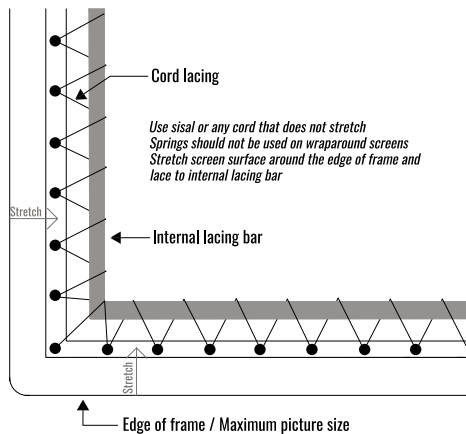

► Wrap around mounting, rear view.  
(Source: Harkness screens)

### 1.7.3 Roll-up screens

In a multi-purpose room, it might be necessary to be able to sometimes remove the screen. This can be done using a roll-up screen.

For screens up to 5–6 m wide, it can be done in a simple fashion with the screen roll at the top. The screen can be pulled up or down like a roller blind. Of course, such a screen will be sensitive to air movements and other variables, so it is not recommended for permanent installations.

For larger screens, the screen is rolled on a solid aluminum or carbon fiber tube that rolls down with the screen. This way, the weight of the tube will stretch the screen, evening out the screen surface. Mounting such a system requires a solid roof mount, and a lot of mechanics to handle the rolling system safely. The tube must be perfectly horizontal to avoid buckled edges on the screen. Evening out the screen will take some time, so the screen should be rolled down well in advance of the screening.

The cost for such a system is substantially higher than for screens mounted in frames.

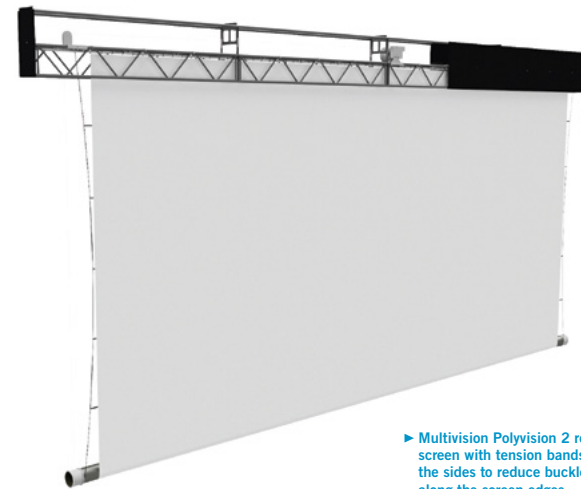

► Multivision Polyvision 2 roll-up screen with tension bands on the sides to reduce buckles along the screen edges.  
(Source: Multivision)

## 1.8 Masking and curtains

### 1.8.1 Screen masking

Screen masking is used to make a nice even frame around the projected image, and to hide the screen mounting in a lace-in system.

Screen masking is mandatory if the auditorium is used to screen analogue film, such as 35 mm or 70 mm. The reason for this is that the projector's aperture, limiting the light from the lamp-house, is not in the same focus plane as the emulsion layer on the film, making the edges of the projected image blurred. Masking will hide the blurred edges and make a sharp frame around the image.

With digital cinema, the edges around the projected image are sharp but not all pixels in the projection system are used. Unused pixels on the screen are not completely black and can be seen as a dark-grey (almost black) edge outside of the picture's edges. To conceal these edges, masking should be used.

The screen masking must be close to the screen surface to minimise the gap, it being visible for people sitting away from the projection axis. It is important to ensure the masking is not so close that it touches the screen and might damage the screen surface.

### 1.8.2 Adjustable masking

It is recommended that the masking is adjustable, to make a nice frame for each format.

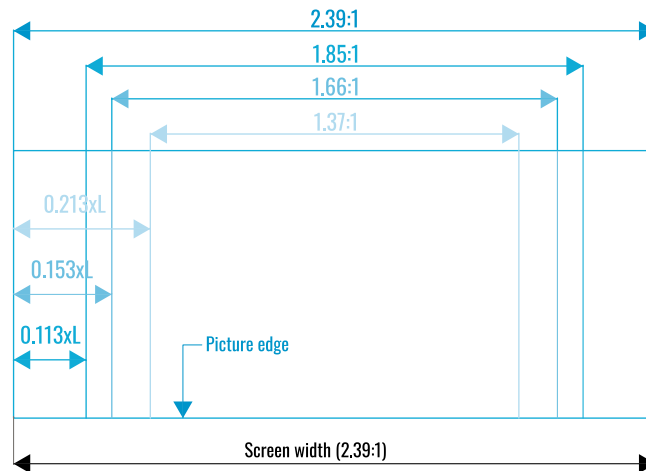

► Variable screen masking of different formats on a 2.39:1 screen with screen width L

On a Scope (2.39:1) screen, moveable side-masking is used. On a Flat (1.85:1), movable top or top and bottom masking is used. To show special formats, like 70 mm film, both moveable side-masking and top-bottom masking may be used.

Masking of the screen frame and masking where no speakers are behind the screen can be made with matte, black, thick fabrics or solid material (no light reflection).

Adjustable masking fabrics, that might be in front of any speakers, must be sound transparent.

The side of the masking, which is towards the picture's edge, should be wrapped around a 150–300 mm wide solid panel in order to give a straight vertical (or horizontal) edge and prevent folds of the masking fabrics from falling into the image.

Masking should be motorised, with preset stops for selected formats and the possibility for manual stops for special formats.

To ensure that the edge towards the image is vertical, it is recommended to use rails and curtain runners in both the top and bottom of the screen.

Changes between formats should be fast and noiseless.

### 1.8.3 Space for movable side-masking

There must be enough space to store the masking fabrics outside of the screen. The width needed depends on the type of fabrics and the suspension system. As a rule of thumb, this formula can be used for side-masking:

$$S \geq 0.3 + 0.05 \times W \text{ (m)}$$

S = free space outside the picture edge on each side  
W = the maximum picture width

#### **Example:**

For a 15m wide screen, the space outside the screen should be a minimum of:  $0.3 + 0.05 \times 15 \text{ m} = 1.05 \text{ m}$  on each side. Different systems might require more or less space.

With this type of side-masking, it is not possible to make wall-to-wall screens.

There are a couple of solutions for masking that require less (or no) space on the sides:

— Black masking panels (200–500 mm wide), without fabric outside of the panels. This will mask the unused pixels outside the picture but will not mask the screen outside the masking panels. In a dark room, this can be an acceptable solution.

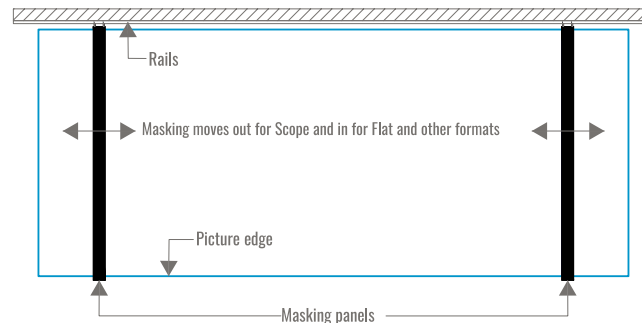

► Saving space on the sides using black masking panels

— Roll-up masking where the masking rolls down to change the masking format. One roll on each side, for each format, or rolls that can slide sideways for different formats.

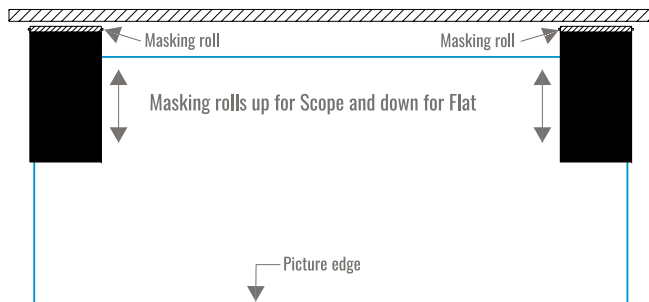

► Saving space on the sides using rollup masking.

#### 1.8.4 Curtains

In auditoriums meant for big premieres, film festivals and multi-purpose rooms where the screen surface needs to be hidden or protected, a main curtain system can be a nice solution.

The curtains' size should at least cover the whole screen system, including masking, but they would look better if they are bigger.

Fabrics for the curtains should be heavy (min 400–500 g/m<sup>2</sup>), with 50–75 % folding.

The curtains must be motorised and, when open, the curtains must not block the view of the whole screen from any seat. And if coloured, the curtains should be hidden to prevent reflecting colours onto the screen.

# 2 Projection

## 2.1 Room for the projector

Digital cinema projectors are noisy, in the range of 40–60 dB @ 1 m for laser projectors and more for xenon projectors, mainly caused by their fans. Therefore, they must be physically isolated from the auditorium. The temperature in the room must be within an acceptable range, typically between 10–35°C for laser projectors. If the air around the projector gets too hot, the lamp/laser life will be reduced and the projector may shut down.

Medium and large xenon lamp projectors will need external exhaust ducting, with an airflow of 800–1000 m<sup>3</sup> per hour. Check cooling requirements with your installer.

### 2.1.1 Projection room

With digital cinema projection systems there is no need for a traditional projection room, like in the old days with 35 mm film projectors. However, a separate projection room still has some advantages:

- Access to the equipment is easy and can take place during the show, avoiding cancellations.

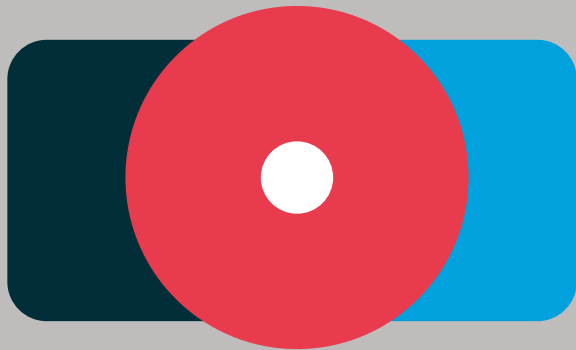

- \_\_\_ Easy access for service and maintenance.
- \_\_\_ Storage for spare parts like lamps, filters, etc.
- \_\_\_ Fuse box for each auditorium, easily available and accessible.
- \_\_\_ Space for processors, servers, amplifiers, light controls, etc.
- \_\_\_ Possibilities for manual operation in case of errors, or if the auditorium will be used for special screenings, events, conferences, etc.

If the auditorium is planned for 35 and/or 70 mm film projection in addition to digital cinema, it is necessary to have a projection room. Usually, the digital projector will be placed between the two analogue projectors. In addition, there must be access to each projector for operation and service.

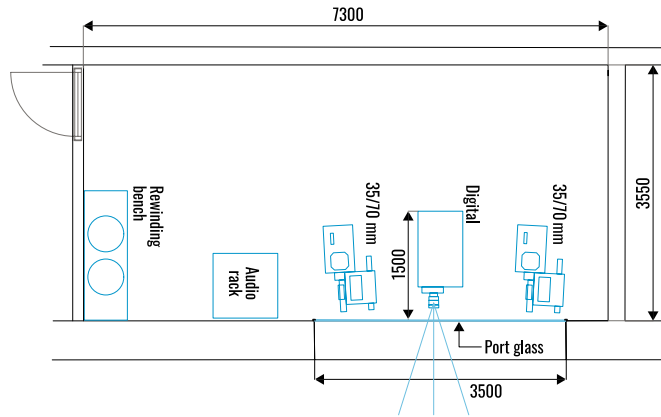

► Projection room example with two 35/70 mm film projectors and one digital projector

### 2.1.2 Projector cabinet

The projector can be installed in a cabinet behind the auditorium, above the ceiling in the corridor behind the auditorium or on the rear wall inside the auditorium. The cabinet must be designed for access to the projector, the quick fix of problems during a show as well as repairs and maintenance. It must meet requirements for sound isolation and temperature control inside, as well as necessary cooling. Fire regulations may also apply.

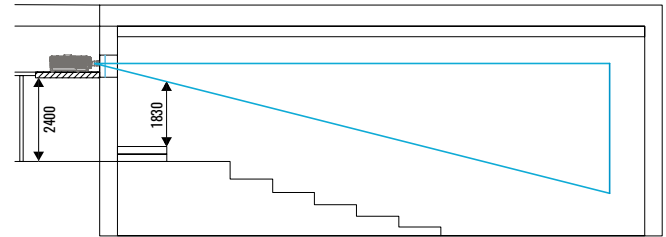

► Projector mounted above the ceiling in the corridor behind the auditorium

### 2.1.3 Boothless projection

With digital projectors, there is very little need for manual operation. Access is still required for service, repairs and maintenance. For example, changing lamps in xenon projectors, filters, etc. and, on rare occasions, fixing or adjusting the projector during a show. To save space, the projector can be mounted inside the auditorium in a box mounted above the audience on the rear wall, or in a box mounted below the ceiling.

If the projector box is located above the rear part of the auditorium, or if the projector is in a box mounted below the ceiling (rather than being behind the rear wall) there are some issues to take into consideration (see also fig. on facing page):

- \_\_\_ The distance from the projector to the screen will be shorter. This will decrease the projection ratio (shorter focal length), reduce the depth of focus and may reduce picture sharpness.
- \_\_\_ Shorter projection throw will increase projection distortion (see Projection angle section below).
- \_\_\_ The clearance under the projector box must meet the requirements for minimum passage height. Projection from the ceiling will usually have a larger projection angle than a projector behind the last row.
- \_\_\_ The need for clearance under the box may limit the level of the last row and may reduce the sightline clearance.
- \_\_\_ Having a large box inside the room will have a negative influence on the acoustics, especially if the auditorium has an immersive audio system.
- \_\_\_ If the projector is hanging from the ceiling and there is a minor problem with the projector during a show, the audience will have to leave the room for the problem to be fixed and the show might be cancelled.
- \_\_\_ The projector box must be soundproof, to eliminate noise from

the projector which could be heard in the auditorium and it must have a quiet air supply. This can be difficult (and expensive) to achieve.

- \_\_\_ If the auditorium has a room-in-room construction to improve sound isolation, the weight of the cabinet with projector might prove a challenge in terms of the inner box construction.

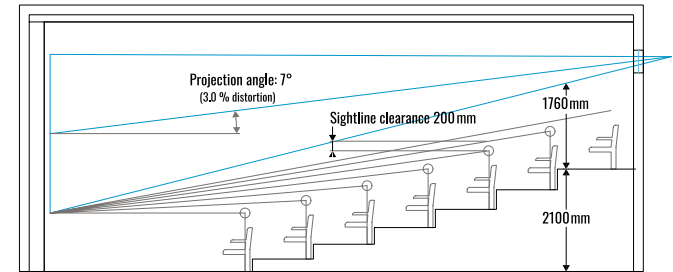

A: Auditorium with projector behind the rear wall

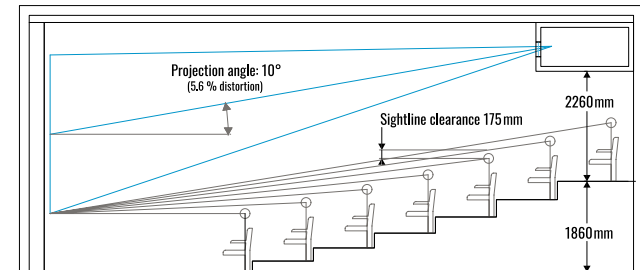

B: Auditorium with boothless projection

- ▶ Two versions of the same auditorium. Top version has the projector behind the last row, bottom version has the projector mounted in the ceiling (boothless).



## 2.2 Projection angle

The projection angle is the angle between the projection axis (or centerline), from the lens to the centre of the screen, and the perpendicular to the screen. This can be seen in the illustration for the Position and tilt section above. The projection angle has a vertical and a horizontal component.

Usually the projection lens is located higher than the centre of the screen so the distance from the lens to the top of the image is shorter than to the bottom. The result is a picture that is wider towards the bottom, called vertical keystone. If the projection lens is located off the centre of the screen's centerline sideways, the image will be higher on the opposite side (see illustrations below).

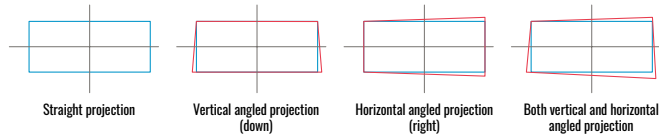

► Picture shapes with angled projection.

### 2.2.1 Distortion

The projection distortion increases with the projection angle and with the ratio between the picture size and the projection throw (distance from lens to screen). Increasing the screen size makes the projection angle more critical.

$$\text{Vertical projection distortion: \% Keystone} = \frac{H}{P} \times \tan \delta_v \times 100\%$$

$$\text{Horizontal projection distortion: \% Keystone} = \frac{W}{P} \times \tan \delta_h \times 100\%$$

$\delta$  = Projection angle (vertical or horizontal)

P = Projection throw

H = Max picture height

W = Max picture width

For good projection, the keystone should be less than 3%. Up to 5% is acceptable.

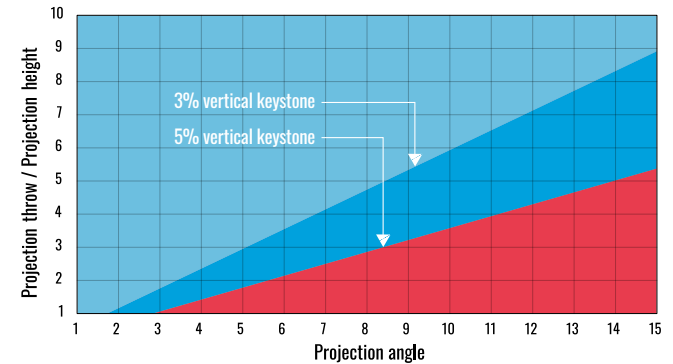

► 3 and 5% vertical keystone relative to vertical projection angle and relative screen size.

### 2.2.2 Lens shift

Digital cinema projector lenses usually have a lens shift functionality to reduce vertical and/or horizontal keystone. To do this, the lens is adjusted horizontally or vertically relative to the optical axis, moving the projected image sideways or vertically without changing the image geometry.

Even minor lens shift adjustments will have a negative impact on the picture quality. The acceptable lens shift range will vary with types of lens and projector. Consult the manufacturer or installer for advice.

## 2.3 Porthole

The main purpose of the porthole, which is the window between the projector and the auditorium, is to prevent noise leaking from the projection room or cabinet into the auditorium. If the projector is in a different fire safety cell than the auditorium, the porthole must also meet requirements for fire protection.

### 2.3.1 Porthole size

The porthole must be large enough for projection in any possible format and, if necessary, have additional width to allow viewing

the screen through the window next to the projector. If the wall between the projector and the auditorium is thick, the porthole must be larger. Chamfering the bottom edge of the opening on the auditorium side can be a solution (see illustration below).

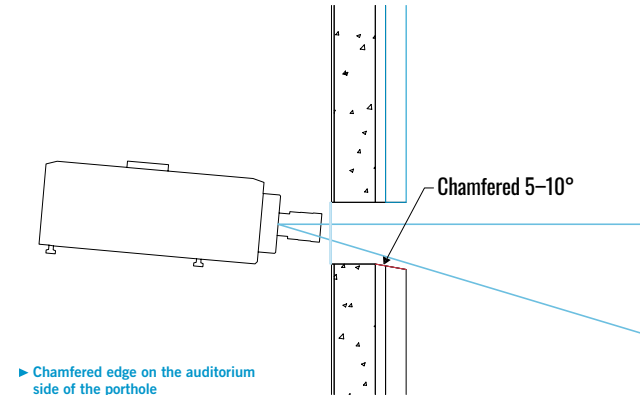

The internal height of a porthole is usually around 400 mm, and the width around 800 mm. If observing the screen through the glass is a necessary addition, increase the width to 1200 or 1400 mm (or more).

Some 3D systems might require larger porthole size because of special attachments in front of the lens. If 3D is an option, check

necessary size (usually height) with the installer or the manufacturer of the 3D system.

For dual projection systems, it is common to stack the projectors. In such cases the porthole height must be higher. Check with the projector installer/manufacturer as to what size is required.

The projection room might contain additional projectors, such as two 35mm or combined 35/70mm projectors. Position them symmetrically, with the digital cinema projector on the centre axis and with enough space between each of them for operation and service. See drawing in the Projection chapter.

Do not make the porthole larger than necessary, because the surface will act as an acoustical reflector in the auditorium and can also be a source of stray light on the screen.

### 2.3.2 Porthole, horizontal position

Horizontally, the projection lens should be on the screen centre axis. If there is more than one projector, with one main projector, place the main projector on the screen centre axis, the second projector on the left side (if possible) and the third on the right side. More than 3 projectors might be a challenge because of horizontal keystone.

### 2.3.3 Porthole, vertical position and clearance under the projection beam

There are different factors that limit the porthole's vertical position:

- \_\_\_ The projection angle must not be too big (see the Projection angle section above).
- \_\_\_ There might be limitations given by the floor level and internal height of the projection room/cabinet.
- \_\_\_ There must be enough clearance under the projection beam on the row in front of the projector (usually last row) to avoid seated people – intentionally or accidentally – making shadows on the screen. One can expect people to bow their heads when passing the beam. Measured in the front of the row in front of the projector, a 1700 mm clearance from floor to the beam's bottom is acceptable. If critical, the clearance can be reduced to 1600 mm.
- \_\_\_ Avoid conflict between the porthole and the surround speakers on the rear wall (see Speaker placements section later in the book).

### 2.3.4 Porthole glass

#### Optical requirements

Use anti-glare and anti-reflective coated optical glass, that transmits 98–99% of the light. Angle the glass surface relative to the projection axis for best results.

### Sound isolation

Thicker glass will give better sound isolation. If single glass is used, the thickness should be 8–10mm and carefully mounted to make it as soundproof as possible.

For even better sound isolation, use double glass. To avoid internal reflections between the sheets of glass becoming visible on the screen, Dolby has recommended a solution where the glass closest to the lens is angled at  $7^\circ$  and the other  $-15^\circ$  relative to the projection axis (see illustration below).

Use sound-absorbing material at the top and bottom, between the sheets of glass. For best acoustic performance the two pieces of glass should have slightly different thickness.

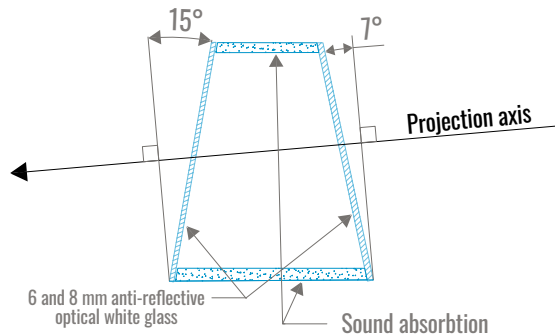

► Double glass porthole.  
(Source: Dolby)

### 2.3.5 Fire protection

If the projector is in a different fire compartment than the auditorium, the porthole must be fire resistant. There are two ways to achieve this:

- Use tempered, fireproof, anti-reflective coated glass – like Schott Pyran (AR) – with acceptable optical properties for 2D projection, mounted in a fireproof framing system. For 3D using polarisation, this type of glass may partly depolarise the light and increase ghosting and is therefore not recommended.
- For better performance, and if polarised 3D projection might be used, use anti-glare and anti-reflective coated optical glass and secure the window with a fire door or curtain that is activated and protects the porthole in case of fire. This is similar to what was done in the past when nitrate film was still used in cinemas.

### 3 Direct view displays for cinema

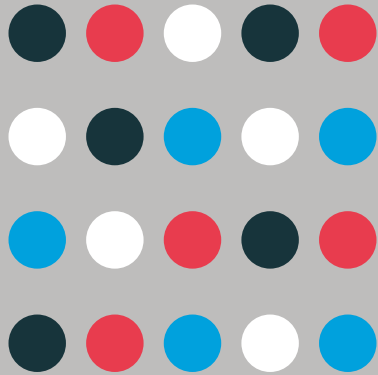

A direct view cinema display is similar to a huge TV-screen. Instead of projectors projecting pixels (or grains) on a screen, the display is made up of active LED panels. Each pixel consists of 3 diodes emitting red, green and blue light (see photos below).

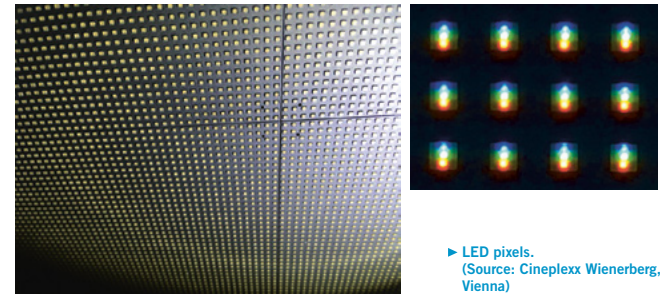

► LED pixels.  
(Source: Cineplex Wienerberg,  
Vienna)

With a direct view display, most issues discussed so far in this book can be ignored, with a few exceptions described below. Most of the contents in the following chapters will apply to both projection screens and direct view displays.

## 3.1 Display format

A direct view display has a fixed aspect ratio, with 2160 x 4096 pixels (4K) or 1080 x 2048 pixels (2K). Any picture format with aspect ratio above 1.90 (2048/1080) will be letterboxed and aspect ratios below 1.90 will be pillarboxed. Flat format will have a picture width that is 2% smaller and a height that is 20% larger than a Scope picture.

Non-active pixels will not emit any light, and the display will be nearly black when the pixels are turned off, so there is no need for screen masking.

## 3.2 Display size

The size of a direct view display is given by the pixel density. For example, a 4K display (4098 pixels wide) with 2.5 mm pixel pitch (pixel density) will be 10.24 m wide and 5.4 m high. There are limited LED panel types, with different pixel pitches, available. The limited display size limits the auditorium size, and the auditorium should be designed relative to the display size. At the time of writing, there are 3 display sizes available from Samsung, called Samsung Onyx:

**2.7 x 5.1 m (2K)**

**5.4 x 10.2 m (4K)**

**7.4 x 14 m (4K)**

There are other systems, from other manufacturers, approved by DCI, but none of them are installed in regular cinemas at the time of writing this book.

Other sizes from Samsung or other manufacturers will probably be available in the foreseeable future.

## 3.3 Depth behind the display

The display itself, with the panels mounted in a rack, has a depth of about 0.5–0.6 m. In addition, the display must be accessible from behind for service, maintenance, etc. The depth from the display front to the wall behind will therefore have to be in the range of 1.0–1.5 m. This is approximately the same as in traditional auditoriums with projection screens.

## 3.4 Luminance

With direct view displays the luminance can reach about 10 times the luminance of a projected image (or even more). That opens up many new possibilities for filmmakers to tell their stories but, as is often the case with new technologies, it can also be misused.

With a black display background, instead of a white screen, black in the picture will still be close to black even if the auditorium house lights are on. This provides the ability to use the auditorium beyond showing films in a dark room, like serving drinks and food. But be aware that turning the house lights on will also make all other elements in the auditorium visible and disturb the film experience. Showing films with the house lights on will be closer to watching films on a TV-screen at home, and that is not what the cinema-going experience should be.

# 4 Viewing conditions

## 4.1 Screen to first row distance

The maximum picture width limits the distance from the first row to the screen on a 2.39:1 screen. On a 1.85:1 screen, both the maximum picture height and width might represent limitations. Sitting too close to the screen, the human visual system will not be able to perceive all the action on the screen and it will not be possible to recognise symbols and read subtitles with only minor head movements. The result is often a reduced cinema-going experience, and a possible headache.

► Human head movement and field of view from above

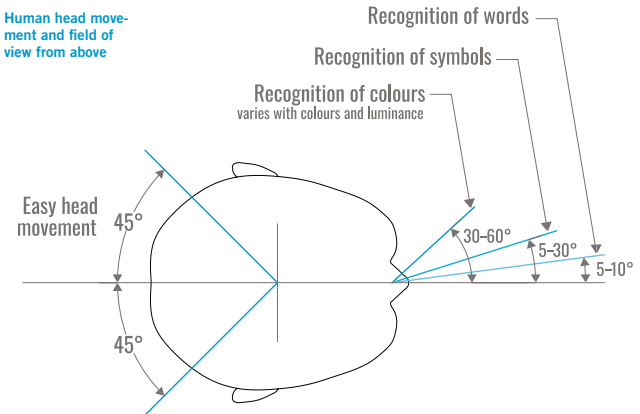



Horizontal field of view between the edges on a 2.39:1 screen that is less than 80° is comfortable, corresponding to a distance from first row (eye) to the screen:

$$D_1 \geq 0.6 \times W$$

$D_1$  = distance from screen to first row (eye position)  
 $W$  = maximum picture width

Maximum field of view should not exceed 90°, corresponding to:

$$D_1 \geq 0.5 \times W$$

See illustration in the Seating area section below.

For 1.85:1 screens, the height will often limit the distance to the first row, as described in the Vertical viewing angles section below. In addition the horizontal field of view in the human visual system is much larger than the vertical, so if the vertical field of view is large, it might be difficult and unpleasant to perceive the action on the screen.

## 4.2 Horizontal viewing angles

If the viewer is seated off the screen's centre axis, a two-dimensional picture on the screen will look distorted. To a certain degree, the human visual system compensates for this distortion but it will gradually become worse as the angle increases, before it becomes unacceptable for the viewer.

The distortion is given by:

$$n = \frac{d}{d_1} = \frac{1}{\cos a}$$

$n$  = distortion,  $d$  = diameter of circle on screen,  $d_1$  = apparent diameter  
 $a$  = angle between sightline from eye to centre of the screen and a perpendicular to the screen

See illustration below.

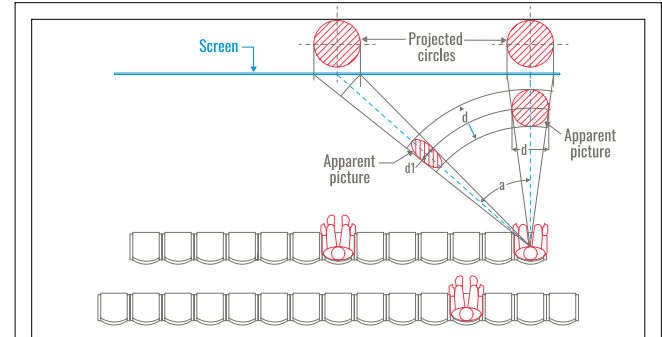

- Good values:  $1 \leq n \leq 1.2$  or  $a \leq 35^\circ$   
 Acceptable values:  $1.2 > n \leq 1.4$  or  $35^\circ < a \leq 45^\circ$   
 Unacceptable values:  $n > 1.4$  or  $a > 45^\circ$

Horizontal viewing angle from any seat to the centre of the screen should be less than 45°.

The observed luminance on the screen decreases when the viewing angle increases. And it is more critical with higher gain screens. With silver screens, the maximum viewing angle must be much lower than  $45^\circ$  (see illustration in the Screen surfaces section above).

Harkness Screens has, for instance, made a Digital Screen Modeller (calculator) that can be used to find acceptable seating area for various of their screen models, available on their website.

## 4.3 Vertical viewing angles

A relaxed, seated person will look  $15^\circ$  downward. The comfortable viewing zone is  $\pm 15^\circ$  relative to this sightline. Such conditions are almost never achievable in a cinema auditorium. However, chairs with head rest and recliners can improve comfort, especially on the first rows.

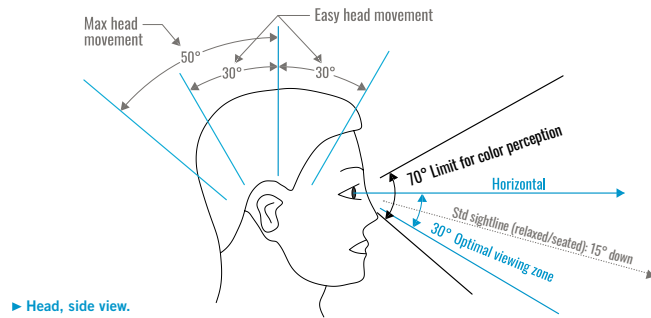

Nevertheless, the vertical viewing angle from first row (eye level, 1200 mm above floor level) to the centre of the screen should be  $25^\circ$  or less (see illustration on facing page). Larger vertical sightlines may be uncomfortable and can cause neck pain.

Some countries recommend minimum  $35^\circ$  angle from eye to screen top, but that will often be in conflict with modern large screens. A maximum of  $45^\circ$  may be a better limitation for sightline to picture top.

On a 1.85:1 screen, the picture top is usually higher than on a 2.39:1 screen. To get acceptable vertical sightlines on a 1:1.85 screen the distance to the first row might have to be larger, and result in less seating rows.

For people sitting in wheelchairs, the vertical sightline to picture top should be a maximum of  $35^\circ$ .

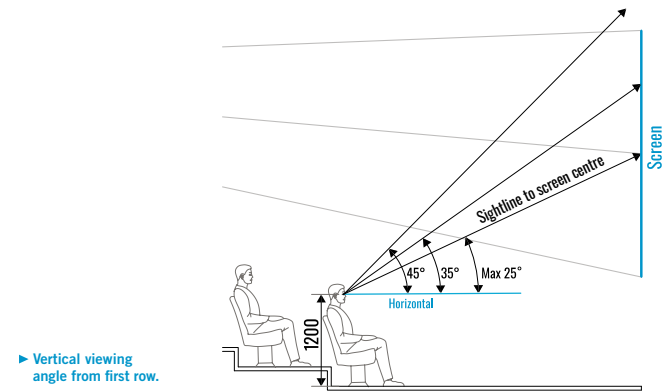

## 4.4 Seating outside the screen's edges

Sitting outside of the screen's edges will reduce the viewer's involvement in the film and reduce the experience. Up to 5° outside the screen's edge is OK. Angles up to 10° are acceptable. See illustration in the Seating area section below.

## 4.5 Safety area in front of large cinema projectors

There are standards and regulations that limit the seating area in front of projectors with high light output, to avoid eye damage if staring into the projection beam. The size of this safe area increases with light output and is also affected by lens type, etc. This issue has become more critical with RGB laser projectors that can deliver higher light output for larger screens or increase the luminance level on the screen (High Dynamic Range).

The standard defines a Hazard Distance (HD), which is the minimum safe distance in the front of the lens. The standard also defines a Separation Height (SH) from the floor to the bottom part of the projection beam. If SH is below 2 m, the area defined by HD must not have any seats and must be labeled as a "No Entry" zone.

See illustration in the Seating area section below.

## 4.6 Seating area

Based on the recommendations given in this chapter, the illustration below shows good and acceptable seating areas in a cinema auditorium.

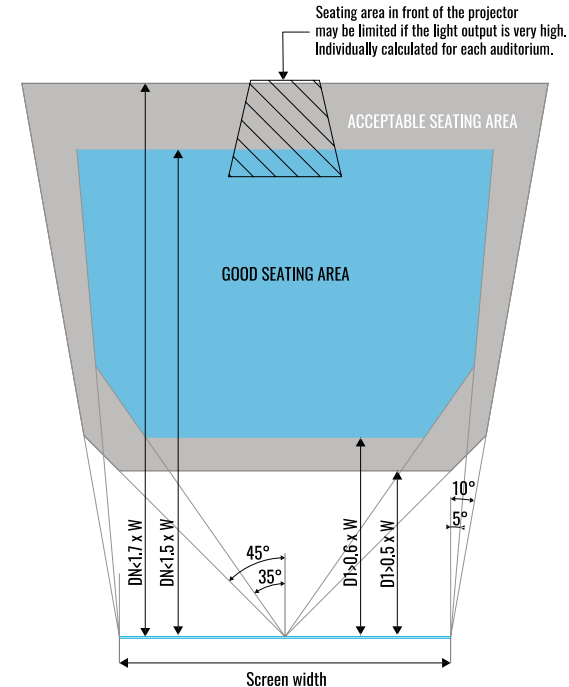

► Acceptable seating area in a cinema auditorium with a 2.39:1 screen. Further limitations might apply, due to the screen reflection (properties).

## 4.7 Sightline clearance

In a cinema, everyone should see the whole picture. To achieve this, the auditorium must be designed to give acceptable sightline clearance from every seat. It is common to use 1200 mm as reference height from floor to eye for a seated person.

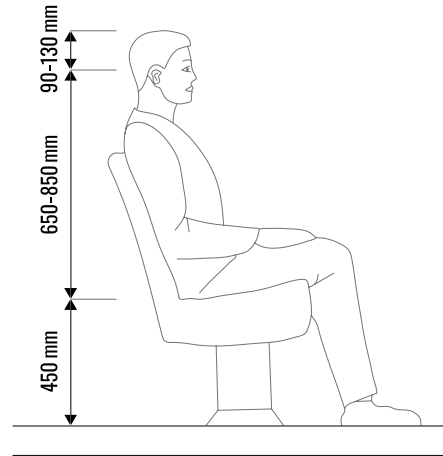

► Seated person.

On a cross section, draw a line from eye position on Row 1 to the bottom picture line, and do the same for Row 2. The clearance between the two lines, measured at eye position on Row 1 is the sightline clearance for Row 2. This should be done for every row in the auditorium (see illustration on facing page). Always use the format with the lowest bottom picture line as reference.

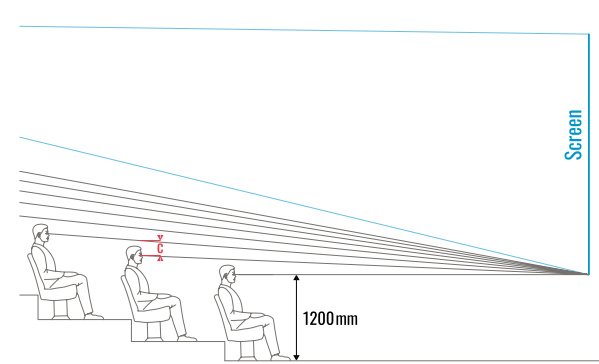

► Sightlines from eye (reference level) to bottom picture line on the screen (sightline clearance = c).

The sightline clearance,  $c$ , must account for the height from eye to the top of the head, and must also account for situations where a taller person sits in front of a shorter person.

Good values:	$c \geq 200 \text{ mm}$
Acceptable values:	$150 \leq c < 200 \text{ mm}$
Poor values:	$120 \leq c < 150 \text{ mm}$
Unacceptable values:	$c < 120 \text{ mm}$

If all the risers have equal heights, the sightline clearance decreases with increasing distance from the screen. To obtain acceptable sightlines from the last rows, the risers might have to be very high, and the total height of the stadium construction will become very high. That will again lead to a larger projection angle and increased keystone. The sound reproduction will also suffer from this.

The ideal solution is to design individual riser heights for each row, calculated to give equal sightline clearance for every row. Alternatively, use lower riser heights for the first group of rows, larger for the next group, etc.

This formula can be used to calculate each riser height with a fixed (common) sightline clearance,  $c$ :

$$Y_n = X_n \left( \frac{Y_1}{X_1} + c \sum_{n=1}^n \frac{1}{X_n} \right) - c$$

$n$  = row number ( $n=1$  for first row, etc.)  
 $X_n$  = distance from screen to row  $n$   
 $Y_n$  = difference in height between eye level on row  $n$  and picture bottom level  
 $c$  = sightline clearance

Sightline clearance can be improved by:

- Increasing the bottom picture level.
- Increasing the distance from screen to Row 1.
- Increasing the stadium height (level last row).
- Reducing the number of rows, making it possible to increase the riser height for each row.
- Decreasing the seating row distance, without increasing the number of rows.

Note that the riser height in front of a crossing aisle must be larger due to increased row distance.

To improve the sightline clearance for small children, a solution might be to offer individual seat cushions that children can borrow.

## 4.8 Stairways in the aisles

The stairways to get from one row to the next in a stadium are different from regular stairways. One could argue that the aisle consists of one stairway per row. But still local regulations might apply. For each row there must be one deep step, to give a safe entrance to the passage between the seats. It also prevents people from stumbling when they go in and out of that passage.

Depending on the riser heights, there will be 1, 2, 3 (or more) steps per row. One deeper step on the row level will be followed by 1, 2 (or more) short steps to the next row level.

If the riser heights are variable, with lower risers in the front, the natural solution might be to have for example 2 steps (1 long and 1 short) in the front, and 3 steps (1 long and 2 short) in the rear of the auditorium. At some point there will be a change between 2 or 3 steps per row. This change might be confusing. Consider using the same number of steps per row for all rows, or all rows in front or in the rear of a crossing aisle. This way the rhythm of walking will be the same, with 1 long, 1 short or 1 long, 2 short steps etc., even if the steps in the front may be very low.

The steps must not be too high. Local regulation probably limits the maximum step height, usually in the range of 200 mm. This means that risers below ~400 mm can have 2 steps (or more), and below ~600 mm can have 3 steps (or more). The tread should be minimum 250 mm (check local regulations).

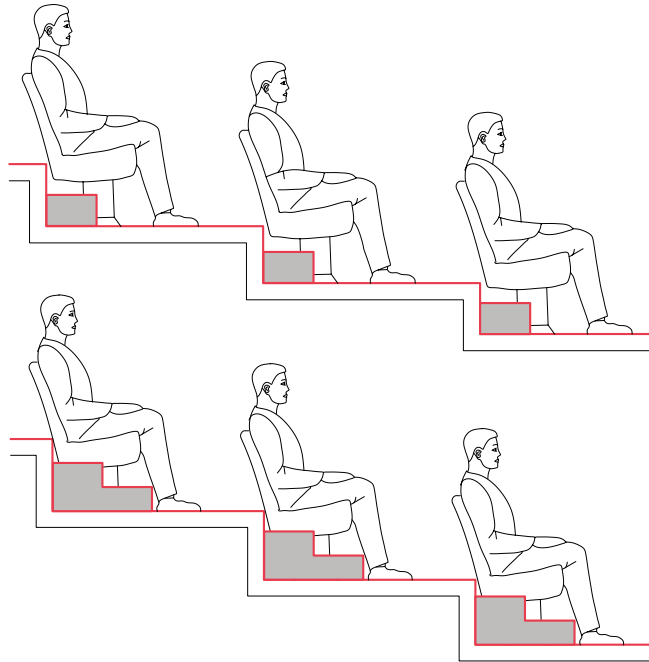

- Above: 2 steps per riser (riser height < ~400 mm).
- Below: 3 steps per riser (riser height < ~600 mm).

Using individual riser heights to optimise sightline clearance will give a small increase in the riser heights from first to last row. The increase per row is small, larger in the front, and less in the rear. The difference is distributed on each step, so the increase is hardly noticeable when walking the aisle in a dark auditorium (the steps are marked with lights). Most people will not even notice that the auditorium slope is slightly curved.

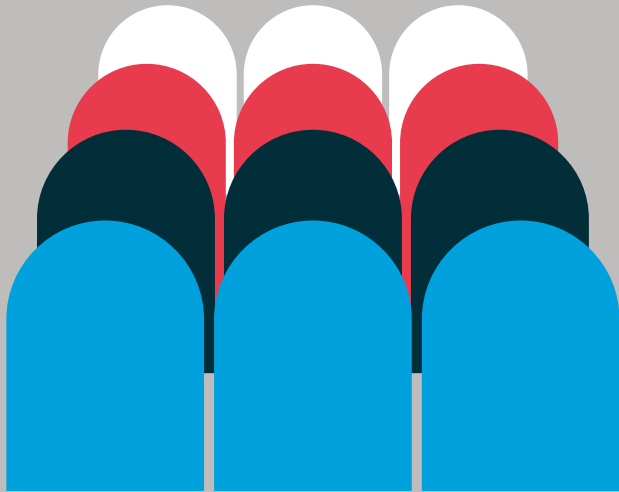

## 5 Seating

Be sure to comply with current rules regarding security, fire safety, accessibility etc. when making the seating layout in your auditorium.

### 5.1 Seating row distance

The seating row distance covers the seat depth and the clearance for access and escape between the seating rows, but should be even larger to offer more leg room and better sitting comfort. The row distance is measured from the back of one seat to the back of the seat in the next row.

Before designing the seating area with rows and risers, it is a big advantage to have decided what type of seating the auditorium will have (see the Seating types section below). Also take into account that trends are changing and other types of seating might require another seating layout if new seats are installed in the future.

For regular seating, the row distance should be 1200 mm or more for good leg room and seating comfort, given that the escape width (see below) is large enough.

### 5.1.1 Escape width

There are different rules for minimum clearance between seating rows, depending on valid regulations and the seating layout.

- \_\_\_ Maximum number of seats between two aisles is usually in the range of 30–50.
- \_\_\_ If there is access to the seats only from one side, the acceptable number of seats between the aisle and the wall is usually half of what is accepted with aisles on both sides.
- \_\_\_ The minimum escape width might be fixed (usually 400–450 mm) or increasing with number of seats (or distance) to the closest aisle (usually 350–500mm).
- \_\_\_ There might be restrictions for maximum distance from any seat to the closest exit door. This maximum distance may also be dependent on the number of exits in the auditorium.
- \_\_\_ Special rules apply for rows accessible for wheelchairs (see Accessibility chapter later in the book).
- \_\_\_ Other restrictions may apply and be sure to comply with all of them.

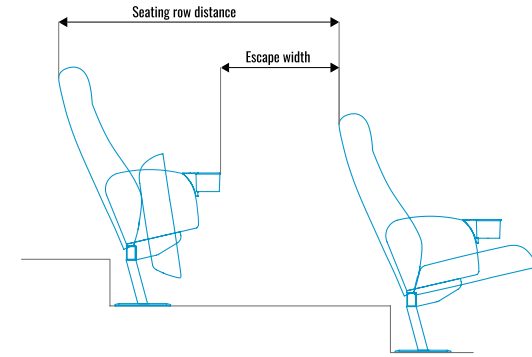

► Seating row distance, and clearance between seating row, for access and escape.

### 5.1.2 Last row depth

On the last row, the row depth must be bigger to compensate for the thickness of the seat back, and because it leans backwards. This extra depth is usually in the range of 150–200 mm. With reclining seat backs, it might be increased to 250–400 mm. Special seating models might require even more depth on the last row. Confirm with relevant seating models.

There are recliner models where the seat moves forward instead of the back of the seat moving backwards, (almost) removing the need for extra depth on the last row.



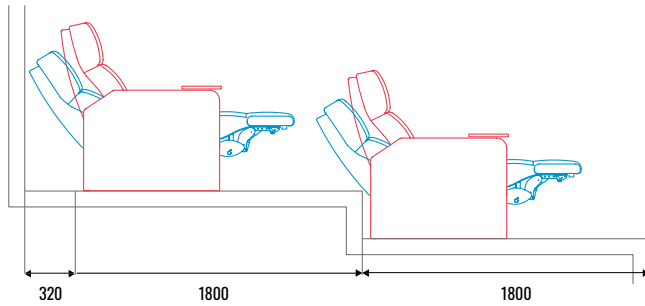

► Additional seating on the last row.  
(Source: Ferco Verona recliner)

## 5.2 Seating types

Cinema seating comes in many different models from various manufacturers and highly variable qualities. Each of them can have a lot of options, e.g. different upholstery, armrests, seat back heights, cupholders/tables etc.

Recliners and some rockers will need power supply for their motors. In addition, power supply is needed if the seats have additional features like electrical outlets, USB/wireless chargers, heating or other options that require electrical power.

Most auditoriums have regular seats (i.e. chairs) to sit in. In some auditoriums there might be “special seating,” like cushions in the front (for children), bed-type seating (on which you can lay down) etc. These types of seating are not discussed in this book.

### 5.2.1 Depth

Regular seating can be divided into 5 main categories (see illustration below):

- **Tip-up seating** refers to seats that tip-up when not in use, increasing the space for passing. To allow people to pass, the seated person must stand up, tip-up the seat and take one step back if the row distance is less than approximately 1200 mm. Seat depth: 500–800 mm with seat tipped-up.
- **Fixed seating** refers to seats that cannot be folded up. With such seats, one should be seated when people pass. They require larger row distance than tip-up seats. Seat depth: 800–1000 mm.
- **Twin seats** (also known as Sofas or “Loveseats”) are similar to fixed seats, but without armrests or with removable armrests (like in airplanes) between the two seats. Seat depth 800–1000 mm.
- **Rockers**, where the backrest can be reclined, often combined with forward seat gliding. The glide function can usually not be combined with tip-up seats, but there are exceptions. Both for security and for making the room look nice when people enter the auditorium, the seats should return to their rest position when they are empty. Seat depth: 700–1100 mm (fixed, empty), 700–800 mm (tip-up, empty).

**Recliners with footrests**, where both the backrest and the footrest are motorised for extra comfort. Separate motors for the backrest and footrest provide for individual preferences. Some seats have an additional separate motor for the neckrest. When a person leaves the seat, the free space in front of the seat must comply with the required escape width. If the seat is not automatically returned to its neutral position (“Auto-Return”), the seating row distance must be larger. Even if the row distance is large enough, it is preferable that the backrest and the footrest have AutoReturn to make the room look tidy before the next show. The AutoReturn system must have a security stop for the footrest, to prevent pinching the foot or hand when the footrest returns. Seat depth: 900–1400 mm (rest position), up to 1800 mm or more with reclined back and footrest up

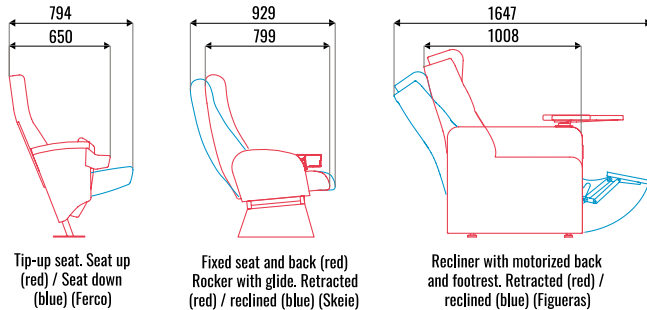

► Examples on seat depths for different types of seating. Varies with models and options.

Cupholders, tables and other accessories may increase the seating depth and require increased seating row distance.

### 5.2.2 Width

Tip-up seats, fixed seat and rockers usually have similar seat width that varies with the width of the armrest (50–150 mm) and can be mounted with shared armrests or double armrests. Seat width: 500–750 mm (shared armrests), 650–900 mm (double armrests).

Recliners usually have wider seats and wider armrests, shared or double. Seat width 650–900 mm (or more).

Tables mounted on the armrests or between the seats will usually require larger width per seat.

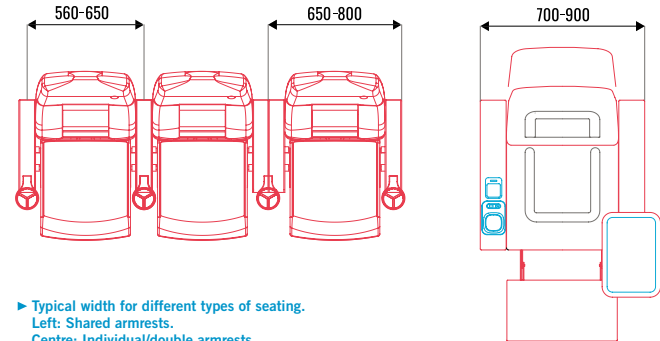

► Typical width for different types of seating.  
Left: Shared armrests.  
Centre: Individual/double armrests.  
Right: Recliner with individual armrests.

### 5.2.3 Height

The height of a seat is given by the height from the floor to the top of the seat back. The same seat model can often be delivered with different seat backs with different heights. A seat back is considered as high if it has support for the neck. As a rule of thumb, heights around 1050 mm or higher can be considered as high and below 1000 mm as low.

## 5.3 Seating quality

There is a wide variety of seating available. The differences are down to construction, cushion, upholstery etc. and it can be difficult to evaluate the quality based on brochures with tech specs or even by testing a model for a short period. Different people should sit in it for at least 2 hours to conduct a more reliable test. Price often reflects the quality, but this is not always the case. References from other installations might be useful and seats should always be bought with extended warranty (5 years or more) for the construction, cushions and upholstery.

There is a European standard for testing seating quality: “EN 12727, Furniture – Ranked seating – Requirements for safety, strength and durability.” The test results are arranged in four levels for different types of use: (1) Light, (2) Moderate, (3) General and (4) Severe. Cinema seating should comply with “Level 4: Severe use”. This is a test of the seat construction and cushions,

but does not include the upholstery (fabric, imitation leather, real leather, etc.).

Fabric durability is often measured in Martindale, where a minimum 70–80 000 Martindale for cinema seating is a common requirement.

Seating with fabric can have a neckrest or neck zone with (imitation) leather which makes it easier to clean, as it is often soiled by hair chemicals, etc.

Armrests are often made with materials that look nice and are easy to clean, like lacquered wood, (imitation) leather, etc. Fabrics on armrests will often look dirty after a short while, due to food and beverage consumption.

Seating fabrics should be treated to withstand spilled beverages, fat etc., and to make them easier to clean.

### 5.3.1 Cushion density

Sitting down in a soft seat might be very comfortable, at least for the first few minutes. But cinema seating must give good support for the back and legs to be comfortable and not make the cinema-goer feel stiff and aching after 2–3 hours. When testing seats, be careful to avoid being misled by your first impression.

## 5.4 Curved seating rows

By curving the seating rows, people in the auditorium will look more in the direction of the centre of the screen, which is more comfortable. Many people also consider curved seating rows to give the auditorium a touch of luxury. But it also raises some issues:

- \_\_\_ The sides of the rows will be closer to the screen and for the first row they may even be too close. This can be solved by removing the extreme seats in Row 1, and maybe some seats on Row 2.
- \_\_\_ If the rear wall is flat and the last row is curved, there will be an empty space in each rear corner. This may look strange and can be more difficult to keep clean.
- \_\_\_ With straight rows, the seating area will look well-arranged and it is easier to get an overview (preferred by many architects).
- \_\_\_ The stadium construction will be more complicated and may be more expensive to build with curved seating rows.

The choice between straight or curved seating rows only has a minor influence on the film experience and may be more related to design taste.

There are different principles for curving seats, some of which are shown in the illustrations on the opposite page.

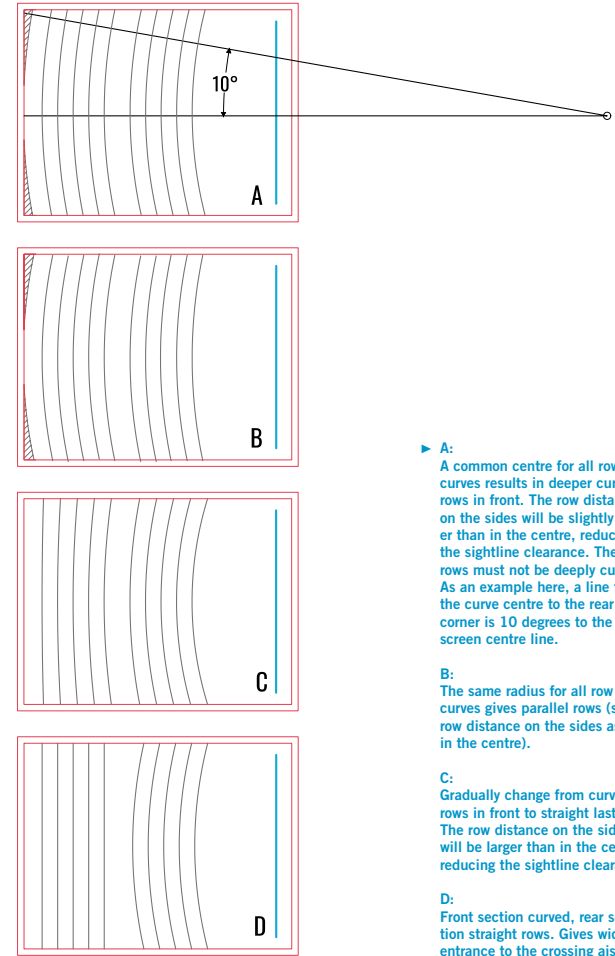

► A:  
A common centre for all row curves results in deeper curved rows in front. The row distance on the sides will be slightly larger than in the centre, reducing the sightline clearance. The rows must not be deeply curved. As an example here, a line from the curve centre to the rear corner is 10 degrees to the screen centre line.

B:  
The same radius for all row curves gives parallel rows (same row distance on the sides as in the centre).

C:  
Gradually change from curved rows in front to straight last row. The row distance on the sides will be larger than in the centre, reducing the sightline clearance.

D:  
Front section curved, rear section straight rows. Gives wider entrance to the crossing aisle, and better access for wheelchairs, etc.

## 5.5 Offset seating rows

It is common to believe that sightline clearance can be improved by offsetting each row by half a seat's width, as shown below. But the field of view between the heads of the two persons in front of you is only 15–30°, which is not enough to see the whole width of the picture. Besides, the people in front of you might for instance lean their heads against each other and make the field of view even smaller. For a person sitting on the side, the head of the person in front can actually be in the sightline to the centre of the screen.

In addition, offsetting the seating rows might reduce each or every second row by one seat.

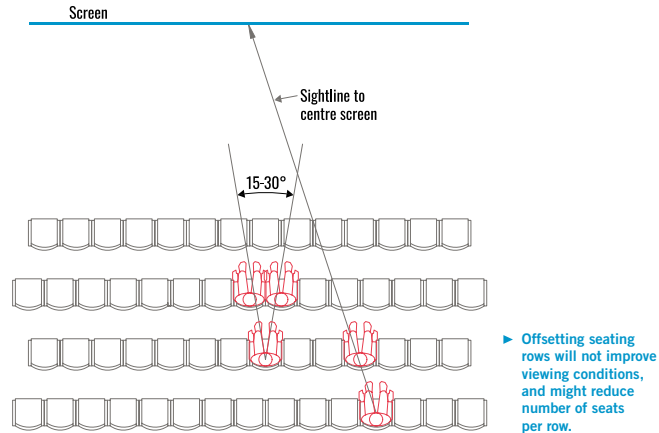

## 5.6 Aisles

Aisles are necessary to gain access to the seating rows and are important for escaping in case of an emergency. The requirements vary in different countries. Be sure to check current local regulations.

Usually there are rules for the total width of all aisles. It can, for instance, be 1 cm per seat in the auditorium. In addition, an aisle must have a minimum width to be accepted as part of the escape system (for instance 1200 mm). Be sure to comply with current rules regarding fire regulations and escape system.

As described earlier in this chapter, the number of seats between two aisles is limited and may have to be reduced (usually halved) if there is only one aisle. For improved comfort, there should not be more than 10 seats between a wall and an aisle. Leaving a small corridor (400–500 mm) from the wall to the closest seat (not part of the escape system) will make those extreme seats more attractive and will improve the sound quality for people sitting there.

### 5.6.1 Crossing aisles

A crossing aisle is either a separate aisle crossing the auditorium, or a row with seats having extended seating row distance to make an aisle in front of them. In both cases, the aisle can fill different needs:

- \_\_\_ It will be an additional possibility to cross the auditorium.
- \_\_\_ It can be used for wheelchairs.
- \_\_\_ If it is designed as a row with extended row distance, it can be equipped with extra comfortable seats (and potentially higher ticket prices).
- \_\_\_ It will give easy access to good seats for VIPs.
- \_\_\_ It can give space for a mixing console (sound and/or light) for special events, such as stage presentations or performances, conferences and debates, film festivals etc.

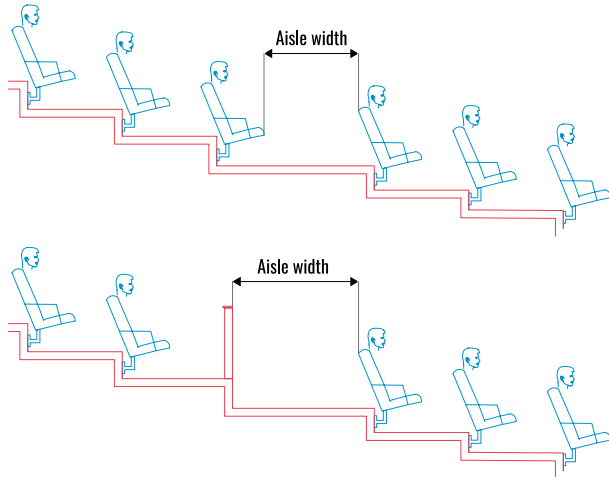

► Crossing aisles. Top: Row distance extended to make a crossing aisle.  
Bottom: Separate crossing aisle, without seats.

If the crossing aisle is on the same level as the entrance, it will give easy access for wheelchairs. It can also be more discreet than an entrance on the first row.

A crossing aisle behind the last row might be useful for a less disturbing crossing, but it will usually require lower stadium height or higher level on the projection lens to get acceptable clearance under the projection beam. This will either reduce the sightline clearance or increase the vertical keystone.

### 5.6.2 Handrails

If there is access to the seating rows only on one side of the aisle, the other side of the aisle must have a handrail. Handrails must be designed according to valid regulations, both related to height above floor and their design. It might be required to have two handrails with different heights.

To make the handrails discreet and prevent disturbing light reflections during the show, they should be as dark and matte as possible.

If the aisle has seating on both sides, handrails are not a good solution. In such cases additional focus must be placed on ensuring it is safe to walk the aisle in a dark room.

## 5.7 Mounting seats

It is common to mount the seats on the floor with one leg stand for every one or two seats.

For easier and faster cleaning, the seats in a stadium auditorium can be mounted on the riser. This requires a minimum riser height, in the range of about 200 mm or more, and a riser construction that can carry this type of mounting. Consult the seating dealer to get specifications for the build.

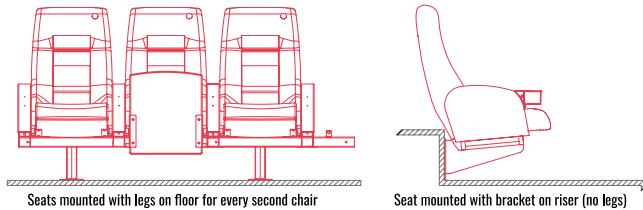

- Floor mounted seats with one leg stand for every two seats (left) and riser mounted seats (right) (Source: Skeie)

Recliners often have four legs per seat and are mounted on the floor. They have motors and will need electrical power. Other seating types may also have four legs, and they may also require electrical power.

## 5.8 Sightline issue with recliners

If the seats have reclining backs, the eye height will be reduced by 50–150 mm when the back is reclined. It will also move the head backwards 50–250 mm (see illustration below). Especially if the person in the seat in front sits upright, this will affect the sightline clearance. Take this into account when designing the auditorium profile to ensure that the sightline clearance is good for everyone, even if the person in front does not recline.

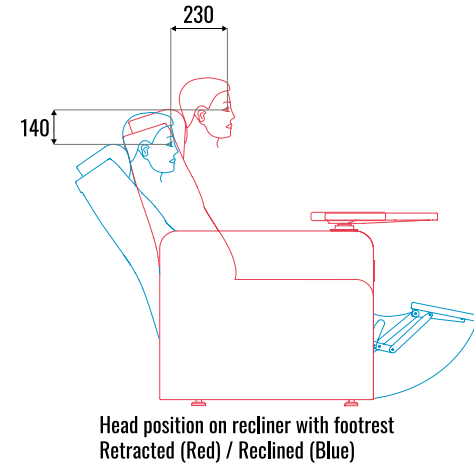

- Example of different head positions with reclining back. (Source: Figueras)

## 5.9 Stadium construction

A cinema auditorium is often designed as a “shoebox” with a stadium construction for the seating area. The stadium construction can be made of wood, steel, concrete or other materials. Often, the room under the stadium is used as a chamber for air, with grids in the risers to let the fresh air flow close to where people are sitting. If this is the case, special considerations must be taken to the air chamber regarding fire safety, acoustics etc. Sprinklers might be demanded. Be sure to comply with current rules and regulations.

If there is an air chamber under the seating area, and the seats are riser mounted, the grids in the risers must be designed in cooperation with the seating installers. The construction must also take into account the extra strength needed for such mounting.

Seating installers often have their own, or an agreement with, people who are experts in building stadiums and mounting seats. They are effective and precise and if there is a problem with the construction or the seating mounting, there is only one responsible party.

The room under the stadium might need acoustical dampening to avoid noise and resonance when people walk on the floor.

There may also be restrictions related to fire safety for the chamber under the seating area.

To avoid step-noise when people walk, carpets in the aisles should be used. Between the seating rows, it is common to use material

on the floor that is easy to clean between shows, like vinyl, linoleum, parquet or other hard surfaces. The floor between the first row and the screen should have dark carpets, both for the acoustics and to prevent disturbing reflections of light from the screen.





## 6 Stray light

Stray light is used here as a term for all unwanted light in the auditorium. There are three main sources for stray light: optical errors in the projection system, reflected light from the screen and direct or reflected light from other sources than the projected image.

### 6.1 Optical errors

Stray light caused by the projection system comes from errors or defects in the optical components, such as the lenses, porthole glass etc. Choosing the right type of porthole glass, as discussed earlier in this guide, and keeping all optical elements clean is essential. Apart from these exceptions, this type of stray light is not considered to be related to the auditorium design.

### 6.2 Reflected light from the screen

When films are screened, the light hitting the screen will be reflected so the audience can see the pictures. Some of the reflected light will hit surfaces that are not black, and a little portion of this light will be reflected back onto the screen. This unwanted light will affect the contrast and reduce the black level on the screen.

Reflected light from coloured surfaces in the auditorium will have an impact on the colours in the projected image. In addition to light reflected back onto the screen, some of the illuminated surfaces will become part of the visual experience, taking the audience's awareness away from the action on the screen.

Future formats, with increased dynamic range (larger span between white and black), will require very low black levels on the screen. Therefore, it will become more important to have dark auditoriums, particularly when it comes to surfaces facing the screen. Ideally, all surfaces in the auditorium should be matte black, including the ceiling, walls, floor and seating, with no reflecting surfaces. For a perfect picture, even the audience should be dressed in black, or there should be no audience at all (but, of course, neither of these is anything a cinema operator wants). A completely black room can be an unpleasant experience, especially for people who don't like being in a pitch-black environment.

At the very least, the walls from the first row to the screen should be black (see Room colours section below).

The room might have decorative lighting on the walls to give it a nice atmosphere, especially for before and after the film screenings and for other uses of the auditorium. Those lamps should be shielded from the light reflected from the screen.

There are many elements that may be disturbing when illuminated by the reflected light from the screen.

- The ceiling should be matte black, without a visible mounting grid (see the Ceiling section below).
- Downlights and other luminaries in the ceiling often have reflectors that will shine like stars when hit by light from the screen. Recommended lighting types are discussed later (see Lighting chapter below).
- Handrails, door handles, ambient light lamps and other elements in the room should be carefully designed so as not to disturb the visual experience of the film.
- Everything behind the screen, facing the back of the screen, must be black. If not, light passing through the screen perforations will be reflected and show up as shiny dots on the screen. However, this will only be seen from specific seats and always in the same spot on the screen. This can be very disrupting for the people in those seats, and these reflections can be very difficult to detect as they are only seen from a few seats.

## 6.3 Other light sources

There can be many different light sources in an auditorium. Some of them will shine on the screen and reduce the contrast. Others, within the audience field of view, may disturb the audience and change how colours and contrast are perceived.

### 6.3.1 Exit doors

When an exit door is opened, light from the adjacent room may shine into the auditorium and disturb the show. The best way to solve this is to have a vestibule protecting the entrance (described in the Acoustics chapter below). In cases without any protection, make sure that the light level outside is low, with no direct light shining in when the door is opened.

Exit doors must be marked with exit lights. Such lights can be a big issue in a cinema auditorium and are described below in the Lighting chapter.

### 6.3.2 Light from the projection room

Traditional projection rooms have lighting in the ceiling covering all or sections of the room in addition to spotlights covering equipment that might be operated during shows, when the auditorium is dark. It is important to prevent any light leaking into the auditorium, obviously with the exception of light from the projector. When the lights go down in the auditorium and the show begins, the human visual system will adapt to the dark room and become more sensitive to light. Even the slightest leak of light from the projection room will be visible on the screen, (often as a light spot) reducing the black level and disturbing or even damaging the film experience. Often, this stray light is so weak that it will only be visible when the human visual system has adapted to the darkness and it will not be visible to the staff coming from outside when loo-

king into the auditorium. Pay attention to this when designing the porthole and lighting in the projection room.

### 6.3.3 Other light sources and visible elements

Sometimes, there can be other light sources in the auditorium, such as a clock on the wall, logos, LED lights from electrical appliances etc. These elements must – when possible and legally permitted – be turned off or shielded from the audience and the screen during the show, or, preferably, removed or made invisible from the auditorium.

## 6.4 Room colours

As described above, light reflected from the screen will hit the surfaces of the room. If the surfaces are not completely black, they will reflect light back on the screen, which may reduce the contrast and influence the colours of the projected image. If the illuminated surfaces are within the audience's field of view, they will have an impact on their visual experience.

Ideally the auditorium should be completely black, except for the screen (and necessary exit lights etc.).

Completely black rooms might be a little unpleasant, but colours in the room must be used with care.

Walls close to the screen should be matte black or very dark. If painted, very matte/flat paint must be used. Oil-based paint should not be used. Walls in the rear part of the auditorium may well be black or very dark. Avoid light colours, especially if they are exposed to reflected light from the screen. Elements shielded from the light from the screen can be lighter and make the room look less dark before and after the film, when the house lights are on. Hidden LED lights can also be used to colour the room.

The floor in front of the screen, especially if the bottom picture line is close to the floor, is of critical importance and should be matte black. Carpets will generally reflect less light than hard surfaces, like vinyl, parquet or painted floor.

The floor in the aisles should also be dark, but any edges and other changes in the flat floor must be marked for security reasons.

Seating colours should be dark. Black would be ideal, but other dark colours may look nicer and are acceptable.

## 6.5 Ceiling

The ceiling should be matte black with no visual grid. If not, reflected light from the screen will make the grid visible and disturbing

(even if it is painted black). The visibility of the grid will vary with the changing light on the screen, making the ceiling even more disturbing. There are ceiling systems available with good acoustical properties, with concealed suspension and no visible grid.



► Black ceiling in a cinema with visible grid.



► “Invisible” ceiling with concealed suspension.  
(Source: Ecophon)

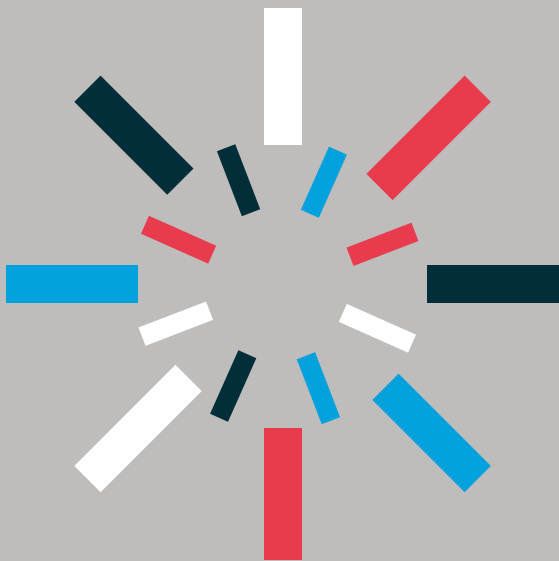

# 7 Lighting

## 7.1 House lighting

The main house lighting system should be discreet and provide even illumination in the seating area, corridors, aisles and floor between Row 1 and the screen.

Incandescent lamps used in the past had the advantage of providing a nice light that changed towards red when dimmed and was dimmable all the way down to 0.0%. Today, this is not an option, so other types of lamps must be used.

Compact fluorescent lamps were used for a while but are now rarely used because of limited dimming possibilities, bad colour spectrum and other factors.

Today, most cinemas use LED lighting. For cinemas, dimming the lights before the film starts is an essential part of the show. And when the film is over, the light should be discreetly lit, starting at 0%. To achieve this with LED, it is necessary to find lamps, dimming systems and control systems that can dim the lamps smoothly beyond 1%.

For nice dimming, there are LED lamps that change colour temperature during the dimming, to give a similar effect as incandescent lamps.

### 7.1.1 Luminaries

Glass and reflectors that are illuminated by light from the screen will shine like stars in the sky at night when there are bright scenes on the screen. One way to avoid or minimise this is by using downlights where the light source is retracted from the opening, with a black baffle between the light source and the opening.

With LED lighting it is possible to find even more discreet luminaries, that barely are visible during the show.



► Discreet lighting example.  
(Source: iGuzzini)

The house lighting is often divided into different zones and/or scenarios, both to create more of a spectacular atmosphere for the beginning and the end of a show and to use the auditorium for other purposes than regular film screenings, including cleaning.

Some RGB LED lamps can change colours, making it possible to change the atmosphere (light level and colour) in the room, for example customised for a film, event or for the audience.

### 7.1.2 Other lights

If the auditorium has curtains, separate lighting on the closed curtains might be a nice option. These lamps can for instance be dimmed when the house lighting is off, when the curtain opens and the screening starts. Without curtains, separate lighting can be used to colour the screen, creating a nice colourful image, or making the screen “glow” and look more impressive. There are lots of other possibilities for a creative light designer.

For visually pleasing presentations on stage, other light sources than the regular house lighting from above will look better. One simple solution is to install vertical rods on each side wall, with stage lights mounted to provide a nice light setting on the stage. Moreover, mounting stage lights on the side walls provides easier access to the luminaries than lights mounted in the ceiling.

The auditorium may have decorative lighting, designer lamps, white or coloured light, logos etc. on the walls. These lights should be controlled by the same system as the house lighting so that they can be dimmed together. Be sure that they are mounted with reflective surfaces, not facing the screen in order to avoid stray light.

### 7.1.3 Light levels

In a cinema auditorium, the 4 most common light levels are given by the table below, with approximate Lux values:

Level	Description	Lux
Full	People enter/leave the room, no screening	150
Half	People enter/leave the room during pre-show or end credits	50
Off	All lights off	0
Max	For cleaning and conferences etc., where people need to be able to read and write	3–400

The luminaries for cleaning may be separate from the main house lighting system but combining them in one system gives more options for different uses of the auditorium.

### 7.1.4 Light control

With LED lamps, it is recommended to use a system that allows the individual control of each lamp in the auditorium. This way it is possible to make nice sequences for different scenarios and to

customise the use of lights for different types of films or events, different types of audiences and so on.

Where the lamps cannot be dimmed all the way down to 0%, dimming the different luminaries with a little offset in time can create the impression that the lamps are dimmed to 0%.

DALI (Digital Addressable Lighting Interface) is commonly used for light control, but other (proprietary) systems like DMX, AMX and others can also be used.

The light control system must communicate with the cinema's automation system.

## 7.2 Emergency lighting

### 7.2.1 Exit lights

All exits in the auditorium that are part of the escape system must be marked with an exit sign that is visible from any seat in the auditorium. When the main show starts, everything is normal and the house lights are completely switched off, permission to dim the exit lights might be given (depending on local regulations). In some cases, and in certain countries, it may even be accepted, under certain conditions, to switch the exit lights off completely. If anything changes, any lights are turned on or anything else happens, the system will immediately turn the exit lights on.

If the exit lights must be on during the show, be sure the light is shielded from the screen.

Exit signs come in many different shapes and designs. Carefully select a model and placement that is as discreet as possible, not leaving a permanent light spot on the screen. This would be really damaging for the viewing experience.



► Example of discreet exit light for cinemas. (Source: Orbik)

### 7.2.2 Stair lighting

Stair lighting is used to mark each step in a stadium auditorium, to make it safe and comfortable to walk the stairs in a dark room, without disturbing people sitting close to the stairways.

Indirect lighting is usually a better solution than mounting the lights directly on top of the steps. Use a system with dimmable lights to avoid lighting that is too bright or too dim.

One solution can be to mount LED rods under the stair nosing, with the light shining down along the riser to the step below. This way the stair lights will be discreet when seen from above, but still provide enough light to see the steps.



► Stair light mounted in stair nosing, shining down along the risers.

### 7.2.3 Guiding lights

In a cinema auditorium there must also be a guiding light system that is activated in an emergency situation. The system should give the audience enough light from the seating to the exit doors, and to find a safe way out of the building. The guiding light luminaires inside the auditorium must be as discreet as possible, not to disturb the film experience during the show.



# 8 Acoustics

## 8.1 Sound isolation

The sound reduction index ( $D_w$ ) is used to describe how well a cinema auditorium is acoustically isolated from its surroundings.  $D_w$  is an on-site measurement in decibels (dB), using a weighting curve close to dBA.

If the noise level in the surroundings are low,  $D_w$  values of 65 dB or higher can be acceptable.

If there are two adjacent auditoriums with shared walls, or other surroundings with high noise levels, the  $D_w$  value must be higher and 70–75 dB is often required. In some cases it may be even higher.

If there is a demand for low noise in the surrounding rooms or other parts of the building, like apartments, offices etc., the  $D_w$  value should be 70–75 dB or higher.

Many elements, like doors, wall systems etc. are part of the auditorium's sound isolation. Such elements are lab tested before installation to measure their sound proofing effectiveness, given as the Weighted Sound Reduction Index,  $R_w$ , measured in dB.

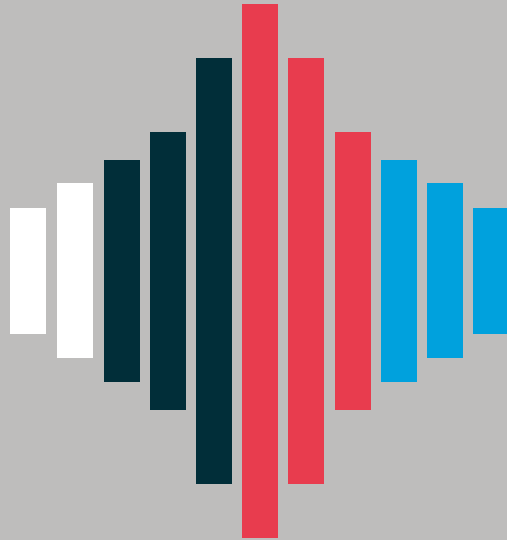

### 8.1.1 Doors

An auditorium has entrance and exit doors and may also have separate emergency exits or doors leading to other rooms (projection room, room behind the screen etc.). If the room on the other side of the door is quiet, a single acoustic door with  $R_w > 45$  dB might be acceptable. For better sound isolation, special acoustic doors with higher  $R_w$  values ( $> 50$  dB) must be used, but such doors are often heavy, made of metal, and are not ideal to operate, especially for the general audience, even if they are motorised. A better solution might be a vestibule between the auditorium and its surroundings.

### 8.1.2 Vestibule

A vestibule is a small room with one door towards the auditorium and another towards its surroundings. The vestibule construction and the doors must be designed to give acceptable noise reduction. Such a room will protect the auditorium from both light and sound leakage from the outside. If the room outside is quiet, the vestibule can be replaced by heavy black curtains to protect the auditorium from light leakage.

All surfaces in the vestibule should be matte black and, if necessary, include lights that can be dimmed during the show.

## 8.2 Background noise

In order to hear every detail in the film's sound, a cinema auditorium must be very quiet. Noise sources are typically ventilation systems, the projector or external noise from other auditoriums, the lobby, outside traffic etc. In screens with RGB laser projectors, there might be noise from so called "screen shakers" that vibrate the screen to eliminate speckle (interference between incoming and reflected light, more visible with higher gain screens or higher luminance).

In the USA, it is common to use Noise Criteria (NC) to specify the background noise. In Europe it is common to use Noise Rating (NR). They are slightly different, as shown on the curves below.

Measurements of background noise are taken in the auditorium, with the ventilation system running, the projector on and the sound volume on fader 7 (reference level), but no audio programme being played. If there are other noise sources in the auditorium, like screen shakers, etc. these should be turned on as well. If there are other cinema auditoriums close by, measurements can be made while they are running ("noisy") films, with their ventilation systems running too.

The noise floor should be lower than NR25 (~NC25), where the noise floor is the closest curve completely above the measured noise. For example, the sample measurement (dotted black line) in the diagram below meets NC25 and NR27 requirements.

## Noise Criteria Curves

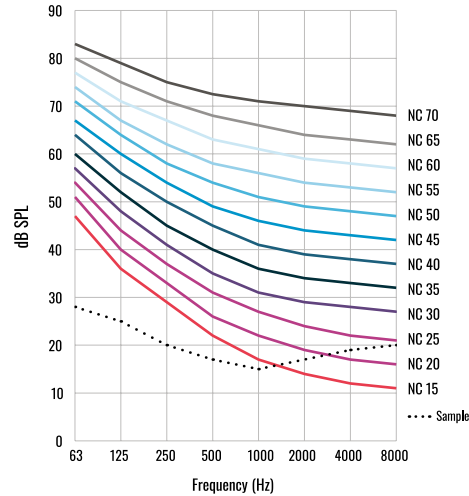

## Noise Rating Curves

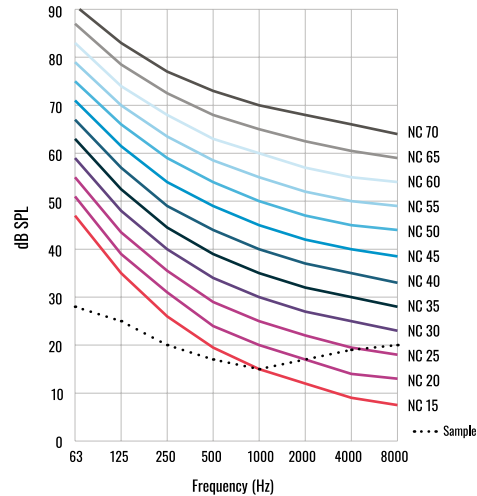

► Noise floor in whole octave bands, including a sample measurement (dotted line). The sample measurement shown complies with NC25 and with NR27.

## 8.3 Reverberation

Sound waves from the loudspeakers will hit the surfaces of the auditorium, where they will be absorbed, transmitted or reflected. Reflected sound waves will hit other surfaces where they will be absorbed, transmitted or reflected, and so on. This way, each sound signal will be audible for a little while. When the sound signal is produced in the loudspeaker, it will take a short time to reach the listener, soon after the first reflections will be heard. The reflections will build up to a maximum and then decay, until the sound signal is no longer audible. This reverberation is measured by calculating the time from the moment the sound is cut to the point where its level is reduced with 60 dB (RT60).

In a cinema, it is fundamental to control the sound to ensure that everyone in the audience will hear it as intended by the filmmaker – or as close as possible. This requires a short reverberation time in the cinema auditorium. In a big room, the reverberation time will be longer than in a small room, so it is acceptable to have a longer reverberation time. See illustration on next page.

Reverberation is frequency dependent. Reverberation time is usually longer for low frequencies than for higher frequencies. The illustration below shows recommended reverberation for different frequencies, relative to the reverberation at 500 Hz.

It is also important for the sound decay to be even, with no significant peaks or dips.

## 8.4 Echo

The speed of sound is about 340 m/s, or about 3 ms/m (depending on temperature and other factors). In a large auditorium, sound reflected from the rear wall, a high ceiling, etc. might have enough delay to be heard separately from the direct sound, resulting in an echo. To hear an echo, the distance from the sound source to the reflecting surface must be more than approximately 17–18m.

Back and forth sound reflections, between parallel walls, will be heard as a flutter echo, a series of echoes occurring in rapid succession.

Eliminating echo effects in a cinema is usually done using sound absorption materials on the walls. Mounting angled or convex panels on the walls to spread the reflections can provide additional support to eliminate echoes.

A curved rear wall, a domed ceiling or other curved surfaces in an auditorium can act as acoustical lenses, reflecting sound to a small area in the centre of the room. In that area, the sound will be louder than in the rest of the room. One can eliminate this effect in the same way as suggested above for echo effects.

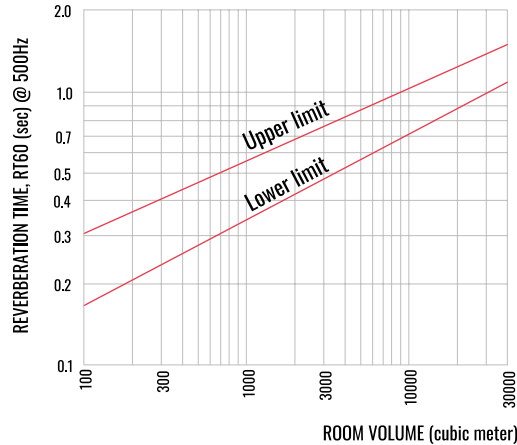

► Recommended reverberation time (RT60) in a cinema auditorium, relative to room volume, measured at 500 Hz. (Source: Dolby)

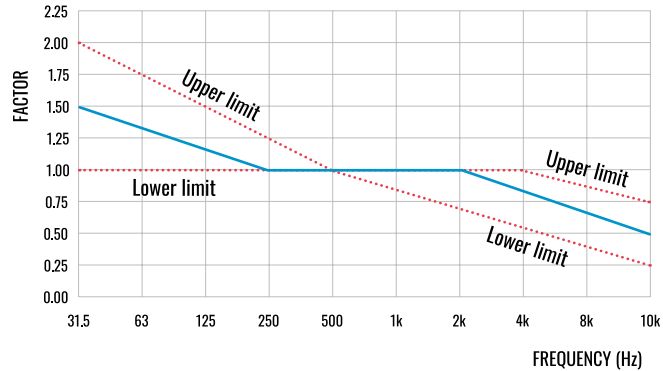

► Recommended reverberation time in a cinema auditorium, relative to reverberation at 500 Hz. (Source: Dolby)

## 8.5 Wall surface

Walls in the auditorium are an important part of the room's acoustical system. Materials used to reduce the reverberation time are usually relatively soft, making them exposed to intentional or accidental damage. To protect the walls from damage, it may be a good solution to use solid, perforated panels, cassettes or similar, with dampening material behind. This will protect the walls, while maintaining their acoustical properties. Be sure to use recommended and proven solutions. And make sure that the panels don't resonate with low frequency sound from the film (creating noise).

# 9 Speaker placement

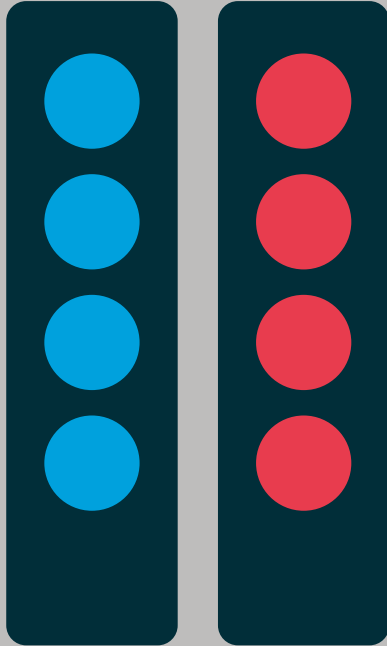

There are different audio systems available. For proprietary immersive systems like Dolby Atmos or Barco Auromax, the type, number and placement of speakers will be given by the manufacturer, along other specifications. It is important to bear in mind that immersive sound formats require speakers mounted in the ceiling. If immersive audio is an option for the auditorium, now or later, preparing for ceiling mounted speakers is highly recommended, and can save lot of work and money if and when such systems are installed.

Direct view displays are not perforated and must have the front speakers mounted above the screen. This choice is also preferred by some cinema chains and installers, claiming it will give better sound reproduction. This chapter will mainly focus on audio for traditional systems, like 5.1, 7.1 and 35/70 mm film, with the front speakers behind a perforated screen.

Different manufacturers/installers/exhibitors might have other recommendations for speaker placements than those described in this book.

5.1 channel audio systems have Left, Centre and Right front speakers behind (or above) the screen. Left and Right surround with speakers on the side and rear walls, with the split between left and right in the centre on the rear wall. There is also a dedicated

subwoofer channel (0.1 channel) with speakers in front, usually below the front speaker (see later in this chapter).

7.1 channel systems have the same front/subwoofer configuration, but the surround is divided in 4 channels: Left Side, Left Rear, Right Rear and Right Side surround channels.

The number of speakers and placements are the same for 5.1 and 7.1 channel systems.

For 70 mm film and 35 mm film with SDDS sound (Sony Dynamic Digital Sound), and for some immersive audio installations, there might be 5 front speakers. The two additional speakers (Left Extra and Right Extra) are placed in the middle between the centre channel and Left or Right front speaker.

## 9.1 Front speakers

Speaker placements behind a perforated screen are described here.

### Screens with 2.39:1 aspect ratio (fixed picture height):

The centre speaker should always be placed on the picture's vertical centerline, with its acoustic centre at  $2/3$  of the picture height from the picture bottom line. The Left and Right speakers should be placed at the same height, midway between the edges of the 2.39:1 and the 1.85:1 picture frame. See illustration on opposite page.

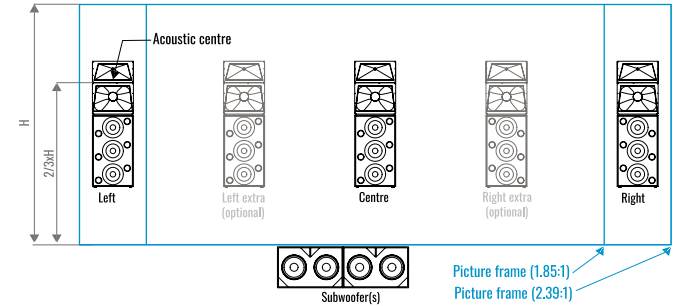

If there are 5 front speakers, Left Extra should be placed midway between Centre and Left speaker, and correspondingly with Right Extra and Right speakers, at the same height as the other front speakers.

### Screens with 1.85:1 aspect ratio (fixed picture width):

The centre speaker is placed on the picture's vertical centerline, with the acoustic centre midway between  $2/3$  picture height for 1.85:1 and 2.39:1 formats, but always so that the speaker's height is within the top and bottom picture lines for both. See illustrations below, showing two situations: One with common picture bottom line for 1.85:1 and 2.39:1 formats, and one with common picture centre line (horizontal) for 1.85:1 and 2.39:1.

The Left and Right speakers should be placed at the same height as the Centre speaker, inside the picture frame but close to the edge.

If there are 5 front speakers, Left extra should be placed midway between Centre and Left speaker, and the same should be done with Right extra and Right speakers, at the same height as the other front speakers.

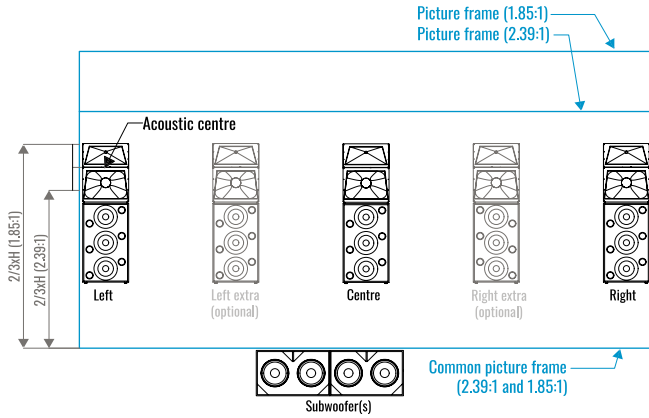

► Speaker placement in 1.85:1 screen format with common picture bottom line.

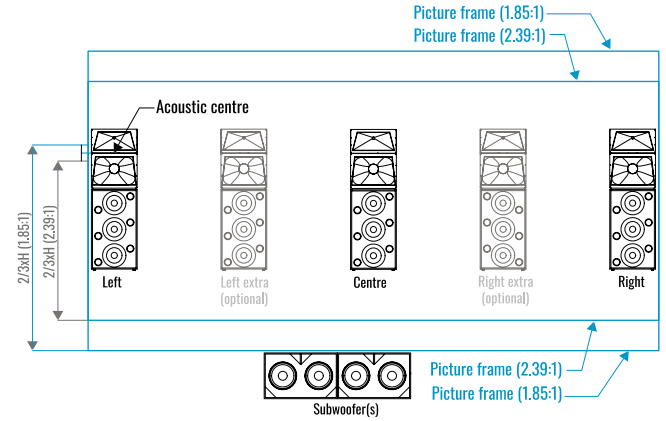

► Speaker placement in 1.85:1 screen format with common picture centre line (horizontal).

## 9.2 Subwoofers

If there is more than one subwoofer cabinet, clustering them will increase their efficiency. The cabinet(s) should be placed close to the picture's vertical centre line, but not on the auditorium centre line, to avoid acoustical issues.

Usually the subwoofers are placed below the centre speaker. Subwoofers may also be placed below the screen frame.



## 9.3 Rear surround speakers

Different manufacturers/installers might have alternative recommendations to those described in this book.

Both in 5.1 and 7.1 audio formats, the surround channels are split at the centre of the rear wall. This favors an even number of rear surround speakers, if the auditorium is symmetric to the screen centre line.

The distance from the left or right corner to the first speaker should be in the range of 0.9–1.2 m.

The speakers should be evenly distributed on the wall with a distance ( $d$ ) between each of them (c–c) in the range of 1.0–2.5 m (maximum 3 m). Smaller spacing will provide better distribution of the sound, especially if the last row is close to the rear wall.

Given the width of the rear wall and the spacing between the speakers, the number of rear speakers should be easy to calculate.

With immersive audio formats, the number and distance between the speakers might be decided by the manufacturer.

All rear surround speakers must be mounted at the same height ( $h$ ) and offer a good coverage of the auditorium. If the ceiling height allows for it, the speakers should be mounted at a height of  $h$ , 2.5–3m above the floor. If not, they should be mounted right below the ceiling.

Ensure that the speakers are not in conflict with the porthole/projection window, and not in conflict with people's heads when they stand up or walk.

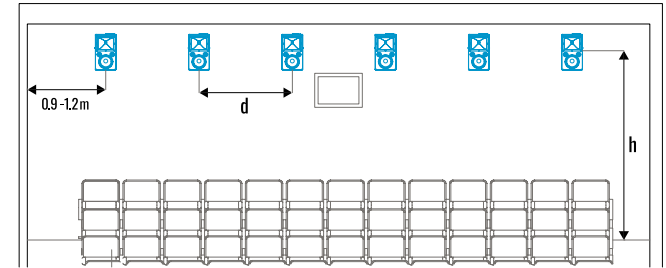

► Rear surround speakers location (example).

## 9.4 Side surround speakers

Different manufacturers/installers might have alternative recommendations to those described in this book.

For 5.1 or 7.1 sound systems, it is common to place the surround speakers with equal height from floor to speaker. The height should be in the range of 2.5 – 3.5 m above the floor. If the room height in the rear is low, the height of the rear side surround speaker might be a little lower.

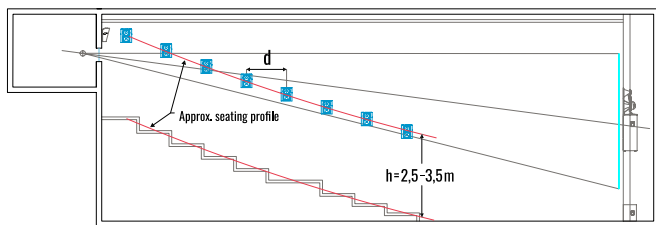

► Side surround speaker location for 5.1/7.1 channel system.

As an alternative, common for immersive audio systems, or to prepare for immersive audio, the side surround speakers can be placed on the side walls, along an axis running from the height of the rear surround speakers to the acoustic centre of the front speakers (shown as a straight red line in the illustration for alternative surround speaker placement below).

The distance between the speakers ( $d$ ) on the side walls should be between 1.0 and 2.5 (max. 3) metres, like on the rear wall. Smaller distance will give more even distribution of the sound in the auditorium.

When placing the side surround speakers, use a similar spacing as the one used for the rear speakers. If the spacing comes out different than the rear wall, the spacing should be slightly smaller for the rear speakers.

The rear side surround speaker should be placed 0.9–1.2 m from the rear wall corner. The front side surround speaker (closest to the screen) should be placed around Row 1 or 2.

For immersive audio systems there might be more surround speakers, closer to the screen, and the number and placement might be calculated according to instructions from the manufacturer of the audio system. Be sure to consult requirements from manufacturers/dealers if such systems are an option.

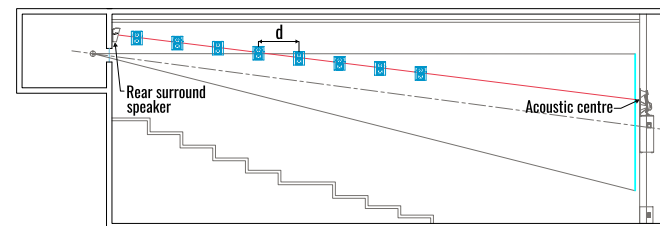

► Alternative side surround speaker location for 5.1/7.1 channel system and for immersive audio systems (immersive audio systems might require other locations and number of speakers).

## 9.5 Mounting surround speakers

There are many different surround speaker models available. Usually they are mounted on brackets where they can be tilted in the desired direction for best coverage.

To mount the surround speakers on the wall, make sure that the wall can safely carry the weight of the bracket with the speaker. It is often necessary to strengthen the walls with studding (for example plywood).

The weight of each surround speaker varies between models and large auditoriums usually have larger speaker models. As a guide-line, one can use this: Small speakers weigh up to 10 kg, while large ones can weigh as much as 30 kg or more. Confirm the weight and mounting system with the sound installer or take account for more heavy speakers.

## 9.6 Baffle wall

A baffle wall is an acoustical wall behind the screen, installed to improve sound clarity and localisation. This wall should be bigger than the screen, with its edge – if possible – 0.9 m or more outside of the left and right front speaker. Usually the baffle wall is built wall-to-wall and floor-to-ceiling, inside the room but separate from the room construction.

If the screen is flat, the baffle wall should be flat. If the screen is curved, the baffle wall can either be curved (following the screen curve) or angled so that the wall has approximately the same angle as the screen in each speaker's position.

Usually the wall is built as a studwork in fireproof 2"x 4" wood for a small baffle wall. Larger walls will require thicker studs, or the wall can be built in steel or other materials. There are also simpler and lighter prefab baffle walls (so called "Bafflettes") available. Make sure that the studs are not in conflict with the front speakers.

On the studwork's side facing the screen, the following layers are mounted (back to front):

- \_\_\_ 1 layer 12–15 mm gypsum board.
- \_\_\_ 1 layer 12–15 mm plywood.
- \_\_\_ 1 layer 12–15 mm gypsum board.
- \_\_\_ 1 layer 50–100 mm sound absorption layer that must be matte black on the side facing the screen.

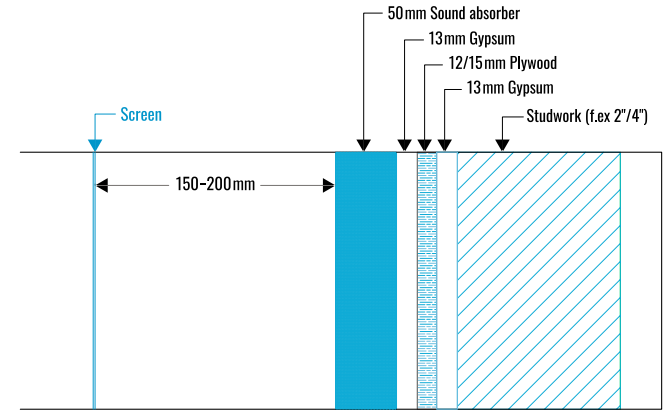

► Cross section detail (example) of a baffle wall, with different layers and thickness.

Each layer is attached to the previous layer inside with screws. The length of the screws should not go through the next layer, to keep the layers independent from each other.

The joints and the screws/bolts on the last, sound absorption layer must be matte black.

The gap between the sound absorber and the screen should be 150–200 mm. If the gap is much bigger it will have a negative effect on the auditorium sound.

The rear side of the stud should be open.

When speaker models are decided, a shelf can be built on the back of the baffle wall, as part of the baffle construction (see illustration on facing page). The vertical position of the shelf is calculated so that the acoustic centre of the speaker is positioned  $\frac{2}{3}$  of the screen height above the bottom picture line (see Speaker placement chapter above).

For each speaker there must be a cut-out in the baffle wall, approximately 5 cm larger than the speakers on each side. The speaker fronts must be approximately in line with the front of the baffle wall, but angled, pointing to the Reference Listening Position (RLP). The RLP is on the screen centre axis, at  $\frac{2}{3}$  of the distance from the screen to the rear wall, in ear height (1200 mm above floor level).

The screen frame with masking system (if any) can be mounted on the front of the baffle wall.

The final baffle wall design should be made by the sound installer, when the speaker models have been selected and the picture size and position is decided.

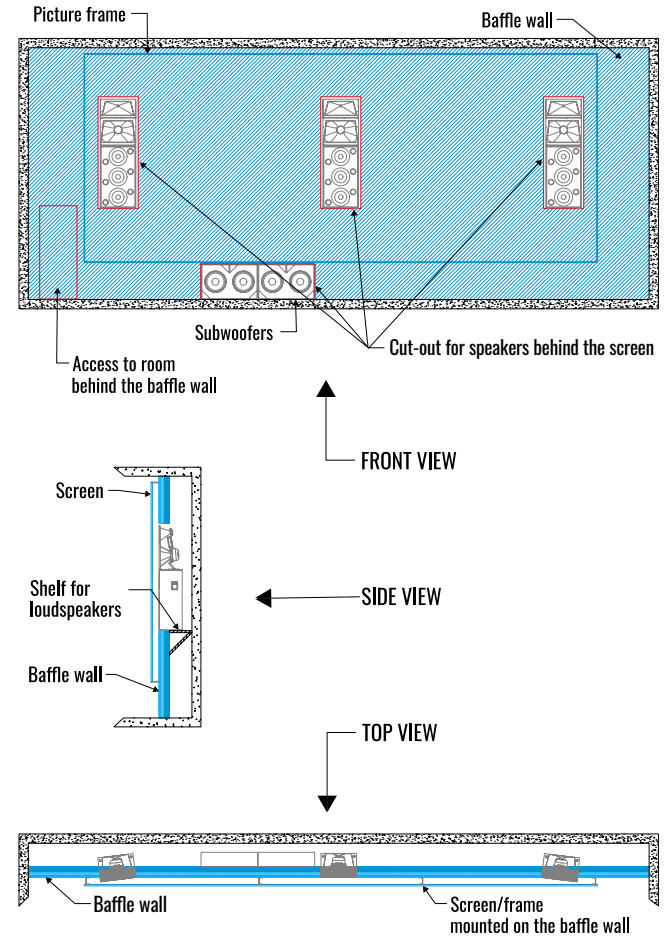

► Baffle wall design with 3 front speakers and double subwoofer cabinets.

### 9.6.1 The room behind the baffle wall

There must be access to the room behind the baffle wall. Sometimes it is easy to make a door from a room or a corridor next to the auditorium, but often access must be through the baffle wall. If so, there should be a door or hatch on one side of the screen, or below it. The front of the door should be covered with the same sound absorption material as the baffle wall, making it almost invisible. If space is limited, the hatch can be as small as 600 x 600 mm (enough for a person to pass through).

There must be working light in the room behind the baffle wall.

Sometimes amplifiers for the front loudspeakers and subwoofers and other equipment are placed behind the baffle wall. If so, there must be power supply for the amplifiers here.

In the baffle room, there should also be power supply for screen masking (if any) and other equipment in the screen area.

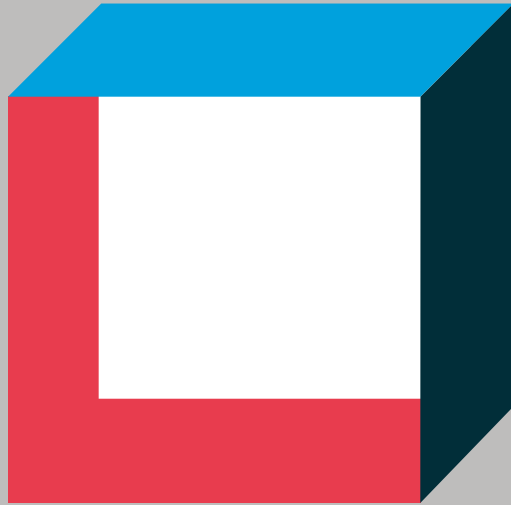

# 10 Auditorium shapes

Cinema auditoriums may have different shapes and dimensions to fit inside the building structure and, for instance, efficiently stacking auditoriums in a multiplex, enabling good logistics in the complex, making the room look magnificent and impressive, improving the acoustics and so on.

Different shapes will usually have both advantages and disadvantages, especially with respect to projection, sightlines, acoustics and design. Some shapes commonly seen in auditoriums are commented upon in this section, referring to other sections in this book.

## 10.1 Room height

The room height in a cinema auditorium depends on where it is measured. If the room is shaped like a shoebox, the room height is often given by the height from floor at Row 1 to the ceiling. Usually there is an internal acoustical ceiling, inside the room. This may be horizontal or sloped, often lower on the screen end of the room. With a stadium, the height will be lower in the rear end of the room. In a cinema auditorium it must therefore always be specified where the height is measured.

Height from the ceiling to the internal acoustical treated roof, can be in the range of 400–600 mm, but may be larger or smaller depending on how the room is designed. The room above the ceiling can be used to mount downlights or other luminaries, emergency lighting, pipes for cabling between the projection room and the stage, surround speakers etc.

Above the screen there should be a minimum height to the ceiling of 50–100 mm, to avoid conflict between the projection beam and the ceiling.

For better acoustics, the height from floor to the acoustical ceiling should be 3000 mm or more on the last row.

From an acoustical point of view, the optimal room height can be calculated relative to the room's length to width ratio (see below).

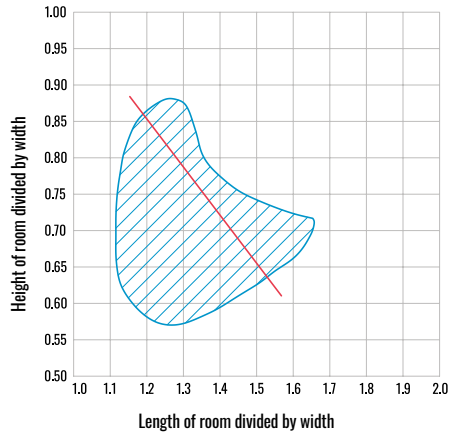

► Room height vs room size.  
Note: Enter drawing with ratio of length to width of room. Proceed up to red line, and then move horizontally to find ratio of height to width.

Example: Length to width is 1.5:1. Move from 1.5 up to the red line, then horizontally to 0.65. Height should be 0.65 x width. Bad acoustics may well result from any design outside the hatched area. (Source: Dolby)

## 10.2 Parallel side walls

For many reasons, parallel side walls – making the room shaped like a shoebox – are very common when it comes to cinema design. A shoebox shape is usually more effective than other shapes when auditoriums are stacked in a multiplex. The shape can give a good balance between the seating area and the picture size, given that the ratio between the room length and width is not too big or not too small. To have enough width for a large picture size, the ratio should be lower than 1.4–1.5. For efficient use of the area, without seats outside the acceptable seating area (see Seating area in the Viewing conditions chapter), a ratio below 1.2–1.3 might be less effective (depending on aisles and seating layout).

Parallel side walls must be acoustically treated to avoid flutter echo (see the Echo section in the Acoustics chapter above).

## 10.3 Angled side walls

In many auditoriums, the side walls are not parallel. If the walls are only slightly angled, this will be good for acoustics and still allow for a large picture size.

If the room is wider in the rear than in the front, this shape may give more seats per square meter, since there are more seats per row in the rear part of the auditorium (see illustration on following page).

If the side walls are angled with the screen wall wider than the rear wall, the screen might look larger and more impressive. But with less seats per row in the rear part, this shape will give less seats per square metre (see illustration below).

- ▶ Right: Auditorium with parallel side walls
- Below right: Auditorium with the rear wall wider than the front wall
- Below left: Auditorium with the front row wider than the rear wall.

All auditoriums have the same length and the same width on the screen wall. Seat width (c-c) = 700 mm, Row distance = 1400 mm (2000 mm on the crossing aisle).

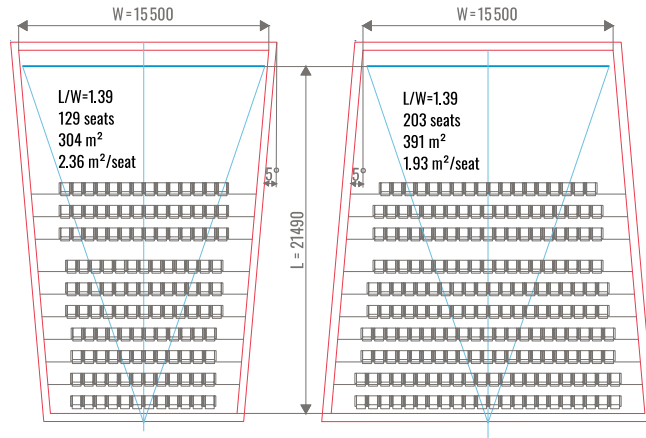
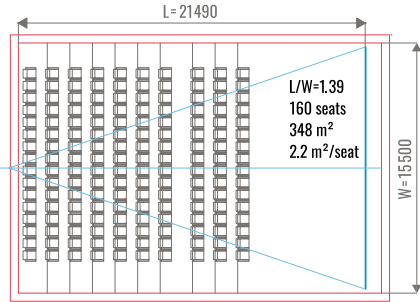

## 10.4 Projection room above the rear part of the auditorium

Sometimes the projection room is built inside the shoebox, above the rear part of the auditorium. This will give projection conditions like those described for Boothless projection (See Projection chapter), with larger projection angle/distortion and less sightline clearance.

The area under the projection room will have significantly different acoustics than the area in front of the projection room. It will be practically impossible to offer equal and correct sound reproduction in both areas, and usually the area under the projection room will not be good in terms of acoustics. If the auditorium is planned to have an immersive audio system, it will be very complicated and expensive to find an acceptable solution.

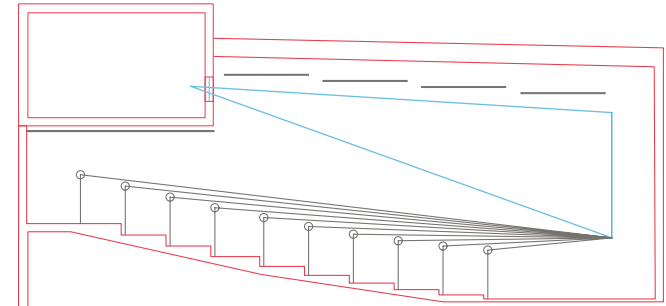

▶ Projection room above the rear part of the auditorium.



## 10.5 Balcony

In the past, balconies were sometimes used in large auditoriums for various reasons, such as increasing capacity and making the room look magnificent (like a theatre). With a sloped floor on the low level, the balcony level did not have to be very high. With the screen mounted high on the front wall, the sightlines on the lower level were not too bad and the rake on the balcony did not have to be too steep. The projector was usually located above the balcony, making the projection angle (very) large. Alternatively, the projector could be mounted below the balcony, but then the front level of the balcony had to be high to make clearance for the projection beam above the seating under the balcony.

A balcony will divide the auditorium into three different acoustical zones, making it extremely difficult to achieve acceptable sound reproduction in all three zones. And it will be even more complicated and expensive to ensure acceptable sound for all seats with an immersive audio system.

Today balconies are rarely used, because it is very difficult to combine large screensize and good sightline clearance with acceptable projection distortion, in addition to complicated acoustics.

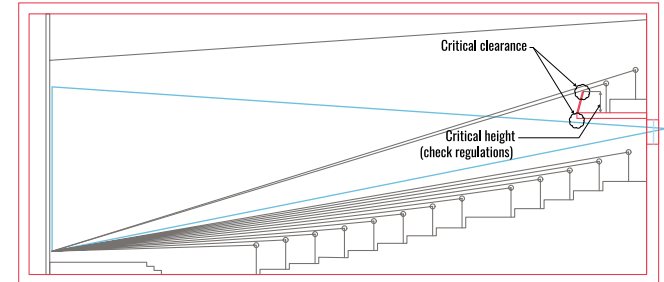

- ▶ Auditorium with 2-row balcony and the projector below the balcony. Clearance for the top of the projection beam under the balcony is critical. Height of the rail in front of balcony must comply with current rules and still give acceptable sightlines to picture bottom even for a small person. Might be difficult to achieve.

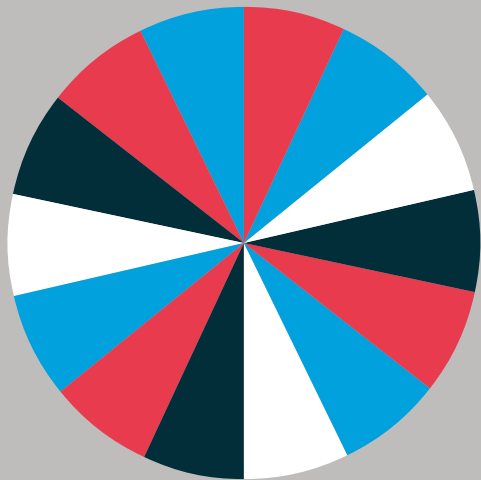

# 11 Accessibility

In this book, the Accessibility chapter is limited to aspects that have an influence on the design of the auditorium.

## 11.1 Wheelchairs

### 11.1.1 Wheelchair access

All auditoriums should be accessible for wheelchairs. In most territories this is regulated by law, but regulations vary from one territory to the other. Local rules may make it mandatory to allow access for a minimum number of wheelchairs in an auditorium, as well as limit where they can be parked and outline necessary space available for each.

In any case, people in wheelchairs should have access to the auditorium through the same corridors and entrances as all other patrons. Using alternative access, like entrances through emergency exits etc., may make the wheelchair users feel like they are a burden to the cinema and not very welcome, and may give the cinema a bad reputation. It may also demand extra effort from the staff to let them in and out.

### 11.1.2 Ramps

There are different rules for ramp slope angles, width, length etc in different countries. Be sure to comply with valid regulations and recommendations.

The gradient of the ramp must not be too steep. The gradient is often limited by the length of the ramp and the rise height. For longer ramps the maximum gradient is usually between 1:15 and 1:20, and for short ramps down to 1:12 might be acceptable.

If the ramp is long, there must be landing for each given rise height (usually between 500–1000 mm) or for each given ramp length. If the total rise height is large, for example over 2000 mm, risers should not be used.

The width of the ramp might be given by the conditions of use or might be given by regulations. Minimum 1200–1500mm is common.

A ramp must have handrails on both sides, with a height from the ramp floor usually in the range of 900–1100mm.

Ramps should not replace stairways, as many disabled people find ramps hard to use.

Avoid using stairlifts and similar devices for vertical transport of wheelchairs, especially inside the auditorium. They are expensive, ugly, (potentially) noisy and most of all: wheelchair users do not like them!

### 11.1.3 Space for a wheelchair

Wheelchairs come in many different shapes and sizes. Required spaces for wheelchairs are different, depending on local regulations. Consider making larger than recommended minimum space for wheelchairs, to accommodate for larger models and easier access.

The minimum parking area for a wheelchair may be different in different countries. Often it is in the range of 900 x 1400 mm (WxD).

In addition to parking, there must be space for access and turning. This may be given as a circle with a diameter that allows for turning the wheelchair, typical around 1500 mm, or as a rectangle where the wheelchair can move forward and turn. Common demands for the size of this rectangle 1300 x 1800 mm. Again, check valid regulations.

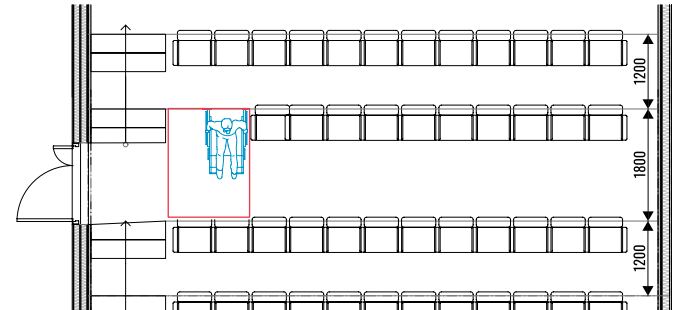

► Necessary space for a wheelchair. The red rectangle marks space needed for access. Demands for the maneuver space varies between different countries/regions.

#### 11.1.4 Number of wheelchair spaces

There may be regulations for number of wheelchair spaces in an auditorium. If not, as a rule of thumb, it is common to go by 1% of total number of seats as fixed wheelchair spaces (minimum 1). In addition, most seating models can be delivered as removable seats, making it possible to have a flexible additional area for wheelchairs, with regular seats when the wheelchair space is not in use.

Next to the wheelchair position there should be a seat for an accompanying person.

If possible, wheelchair positions should be paired, so two wheelchair users can sit together.

#### 11.1.5 Wheelchair locations

There may be regulations on where wheelchairs can be placed in an auditorium. In addition to accessibility, some countries do not accept wheelchairs on the first row. Even if this is not a requirement, it is recommended not to have them on the first row. The first row is usually not preferred by the audience and wheelchair users in general do not feel comfortable sitting there.

Try to find a solution where wheelchairs have access to a premium seating area.

Wheelchairs should be placed on the same level, and not isolated from the rest of the seating area.

If the wheelchairs must be placed on the first row, make sure that the vertical sightline from eye to top of the picture in any format is less than 35°, using 1250 mm as average eye height for wheelchair users.

#### 11.1.6 Entrance and exit doors

To make the auditorium easily accessible for wheelchairs, the entrance/exit doors used by wheelchairs must be step-less. There are step-less systems available that also comply with fire regulations, etc.

Exit doors in a cinema auditorium should have a power assisted door opening system. The opening mechanism should be easily accessible.

The powered door system can also be used to automatically close the door when the film starts and open it at the end of the film.

## 11.2 For hearing impaired people

DCPs (digital film) have an allocated channel for the hearing impaired (HI). But in many countries these tracks are not available in the local language. Instead foreign films are subtitled, and in some countries even domestic films are subtitled.

Many cinemas install inductive loops for hearing aid users. With such systems, it is possible for users to receive a mono mix of the film sound via their own hearing aid device. Inductive loops can also be used for other purposes, when the cinema auditorium is used for is used for conferences, etc.

To prevent crosstalk between different auditoriums and other rooms, a customised double loop is recommended. Each of the loops is usually a cable mounted underneath the seating construction or using a flat cable under the floor covering in the seating area, covering every seat.

Directions for the cable layout and mounting can be given by the installer or the manufacturer of inductive loop systems.

For the hearing impaired the HI track can be used to make subtitles available on separate devices, like pads or phones, and there are also available glasses where the subtitles are generated in the glasses. Such devices require that the subtitles are available in local language.

## 11.3 For visual impaired people

DCPs has an allocated channel for the visually impaired (VI). This soundtrack is a narrative description of the film, explaining the scenes. In many countries the VI track is not available in the local language. Instead, some countries provides the narrative soundtrack, usually only on domestic films, via other systems available for users on their mobile phones.

It is important to facilitate for visually impaired cinema-goers when planning the lighting, and surfaces in the room. If there is a change in the floor level, or other elements that can have an impact when walking, the level change or elements must be marked with colors and lighting, so they are easy to see. There are different rules in different countries, and there is a lot of literature available on how to make the auditorium more accessible for the visually impaired without sacrificing the quality of the film experience.

Some visually impaired people have a guide dog and want to bring the dog with them into the auditorium. For them, there should be seats available where the dog can rest in front of, or under, the seat.

## Thanks

This book would not have been written without the advice and inspiration of many people, companies and published literature.

The EDCF (European Digital Cinema Forum) is planning to publish a Best Practices Guide for Image and Sound, initiated and led by Julian Pinn (Julian Pinn Ltd). I was asked to be the principal author for the part called Architectural Aspects. Without this initiative, this book would not have been written. I owe a lot of thanks to Julian for his initiative and to the cowriters for their valuable input, especially Matt Jahans from Harkness and Tom Bert from Barco.

UNIC (the International Union of Cinemas) went through a major upgrade when they moved to Brussels in 2011 and strengthened the organisation under the leadership of Phil Clapp (President), Jan Runge and later Laura Houlgatte (CEO). UNIC also established a Technology Group, which I have had the great pleasure of being a part of. Its work is now very well organised by Guillaume Branders. I owe him a lot of thanks for all the good work he has done and for his inspiration and help with this book, and his colleagues (Lucy and Chris) for helping me with the language.

I have been working for Film&Kino (the nonprofit trade organisation for Norwegian cinemas) since 1984. As their consultant in cinema technology and cinema design, they have trusted me and always given me the tools I have needed to develop this service. Most of my knowledge I have acquired by working for Film&Kino on cinema projects. Huge thanks to them and all the cinema owners and staff, architects, engineers and consultants I have had the pleasure of working with.

30 years ago, I had the great pleasure of getting to know loan Allen who was the Senior Vice President for Dolby Laboratories in San Francisco. Since then, he has been a good friend and one of my main inspirators. He has always been an important link between filmmakers and cinemas and has written books and many articles aimed at improving the cinema auditorium experience. Thank you, loan!

A special thanks to Mike Bradbury, CTO for Odeon Cinemas UK, for sharing his knowledge and always fighting to improve the cinema-going experience.

Also a special thanks to Rick Williams (Freeney Williams Ltd) for lots of useful feedback and inspiration regarding accessibility.

And last but not least: Thanks to filmmakers for making great films that are screened in cinema auditoriums, and thanks to people who choose to come and see them as intended by the filmmakers in the great cinema auditoriums.

## Literature

- \_\_\_ Planning a cinema (Philips NL, 1964)
- \_\_\_ Guidelines for Design of Effective Cine Theatres (William Sczabo 1986)
- \_\_\_ Technical Guidelines for Dolby Stereo Theatres (Ioan Allen/Dolby, 1984)
- \_\_\_ Various French standards and recommendations (CST, Paris)
- \_\_\_ DolbyAtmos® Specifications Issue 3 (Dolby Laboratories, 2015)
- \_\_\_ Manuals etc from THX Lucasfilm ® (1985-2000)
- \_\_\_ Manuals, brochures, articles etc from manufacturers (Christie, Barco, Dolby, Harkness, QSC, Samsung, Skeie, Figueras, Ferco, Multivision, Ecophon, iGuzzini, Orbik)
- \_\_\_ DCI Specification, Version 1.3
- \_\_\_ ISDCF, various documents
- \_\_\_ EN 12727 Standard: Furniture-Ranked Seating- Requirements for safety, strength and durability
- \_\_\_ Providing Services To Disabled People (UKCA, July 2016)
- \_\_\_ Regulations on technical requirements for building works (TEK 10 and TEK 17) (Norway)
- \_\_\_ Dimensioning for wheelchairs (SINTEF) (Norway)
- \_\_\_ Publications from The Norwegian Association of Disabled (Norway)

Imprint:

Copyright Rolv Gjestland 2020

All rights reserved

Published by UNIC

Version 1.2 (February 2020)

Design: Sandra Ruderer





UNION INTERNATIONALE DES CINÉMAS  
INTERNATIONAL UNION OF CINEMAS